

START HERE!

READ ME FIRST

Don't be a hero and muscle through this installation without reading these fitting instructions first! Improper installation of this gear may void certain aspects of your warranty.

Before you begin, take a moment and open all your Front Runner rack kit boxes and gather the assembly instructions for the various components.

A complete kit will contain:

1. A Front Runner Mounting system specific to your vehicle
2. A Front Runner Rack Tray or Load bar Slats

This document will guide you through the assembly of the mounting system and assist you in fitting the roof rack tray or load bars to your specific vehicle.

Please refer to the next page for a list of all the components, quantities and tools required.

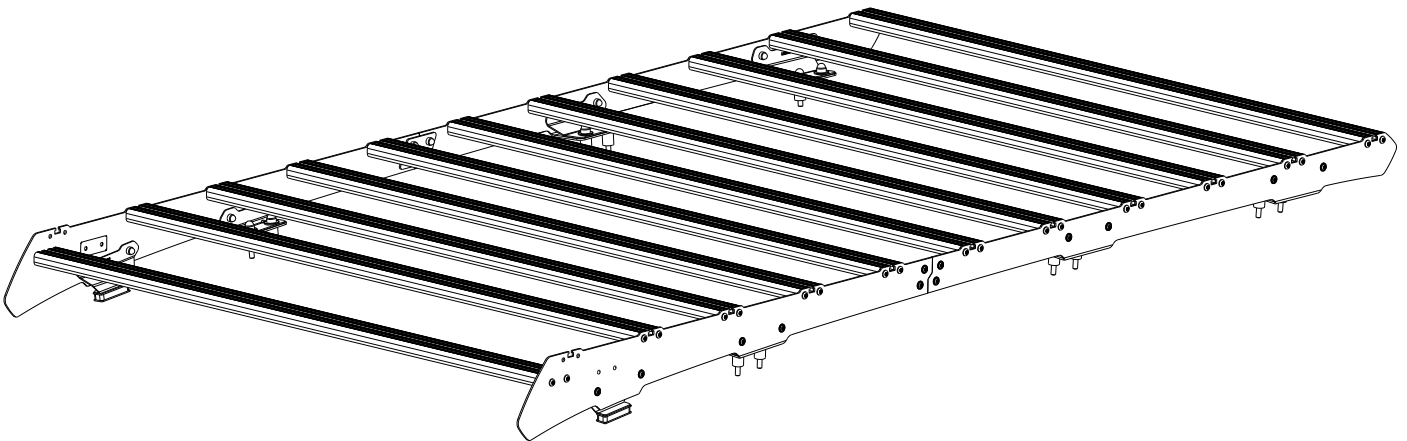

IMPORTANT WARNING!

IT IS CRITICAL THAT ALL FRONT RUNNER PRODUCTS BE PROPERLY AND SECURELY ASSEMBLED AND ATTACHED TO YOUR VEHICLE. IMPROPER ATTACHMENT COULD RESULT IN AN AUTOMOBILE ACCIDENT, AND COULD CAUSE SERIOUS BODILY INJURY OR DEATH. YOU ARE RESPONSIBLE FOR ASSEMBLING AND SECURING ALL FRONT RUNNER PRODUCTS TO YOUR VEHICLE, CHECKING THE ATTACHMENTS PRIOR TO USE, AND PERIODICALLY INSPECTING THE PRODUCTS FOR ADJUSTMENT, WEAR AND DAMAGE. THEREFORE, YOU MUST READ AND UNDERSTAND ALL OF THE INSTRUCTIONS AND PRECAUTIONS SUPPLIED WITH YOUR FRONT RUNNER PRODUCT PRIOR TO INSTALLATION OR USE. IF YOU DO NOT UNDERSTAND ALL OF THE INSTRUCTIONS AND CAUTIONS, OR IF YOU HAVE NO MECHANICAL EXPERIENCE AND ARE NOT THOROUGHLY FAMILIAR WITH THE INSTALLATION PROCEDURES, YOU SHOULD HAVE THE PRODUCT INSTALLED BY A PROFESSIONAL INSTALLER OR OTHER QUALIFIED PERSONNEL.

NOTE: Front Runner will not be responsible for any damage caused by the failure to install the product according to these instructions.

Please call us if you have any questions about the installation of this product.



1 GET ORGANIZED

IN THE BOX

1	2 X	Foot Rail Front LH & RH
2	2 X	Joiner Plate
3	2 X	Foot Rail Rear LH & RH
4	11 X	Slimsport Slat
5	44 X	M6 x 20 Button Head Screw
6	24 X	M6 x 16 Button Head Screw
7	2 X	Front Support Foot
8	2 X	Front /Middle Gusset
9	2 X	Rear/Middle Gusset
10	2 X	Rear Gusset
11	24 X	M6 Nyloc Nut
12	12 X	M8 x 25 x2 Flat Washer
13	12 X	M8 x 50 Hex Bolt
14	12 X	Spcer 19 x 24
15	12 X	M8 Nut Cap
16	12 X	M6 Nut Cap
17	2 X	Front Foot Spacer (with VHB Tape)

TOOLS NEEDED

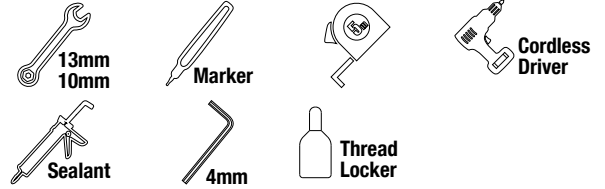
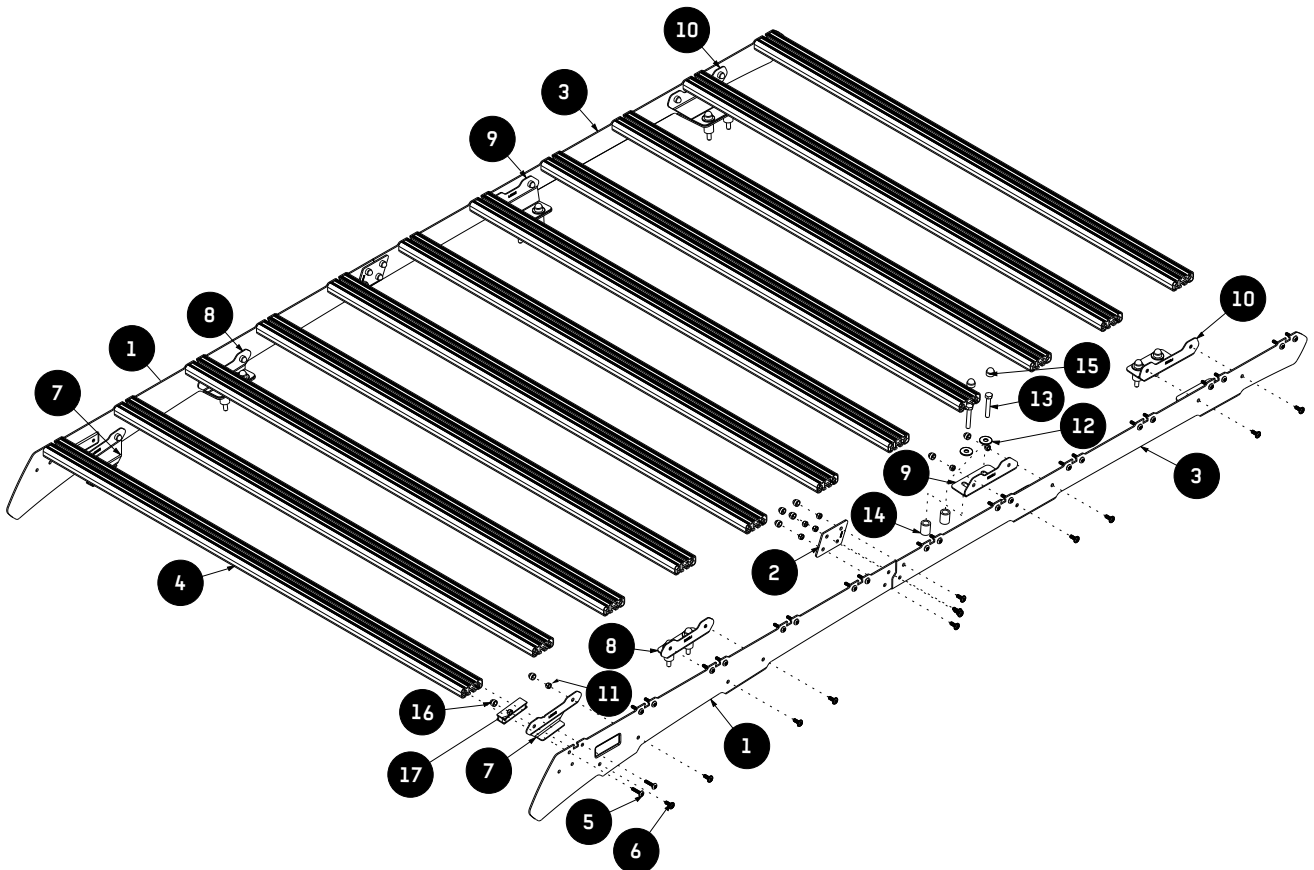

FIGURE 1.1



2

ASSEMBLY

2.1

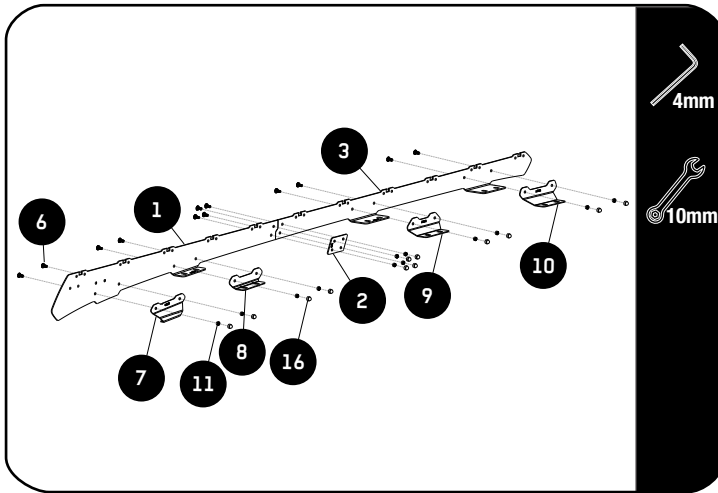

Secure the Joiner Plate (Item 2) to the Foot Rails (Items 1 & 3) as shown using M6 x 16 Button Head Bolts and M6 Nyloc Nuts (Items 6 & 11). Fully Tighten.

Secure the Stiffener Plates (Items 8,9&10) to the Foot Rails (Items 1 & 3) using M6 x 16 Button Head Bolts and M6 Nyloc Nuts (Items 6 & 11). Fully Tighten.

Loosely fit the Front Support (Items 7) to the Foot Rail (Item 1) using M6 x 16 Button Head Bolts and M6 Nyloc Nuts (Items 6 & 11). Fully Tighten.

Do this to both LH & RH Foot Rails.

Place M6 Nut Caps (Item 16) over all Nyloc Nuts.

2.2

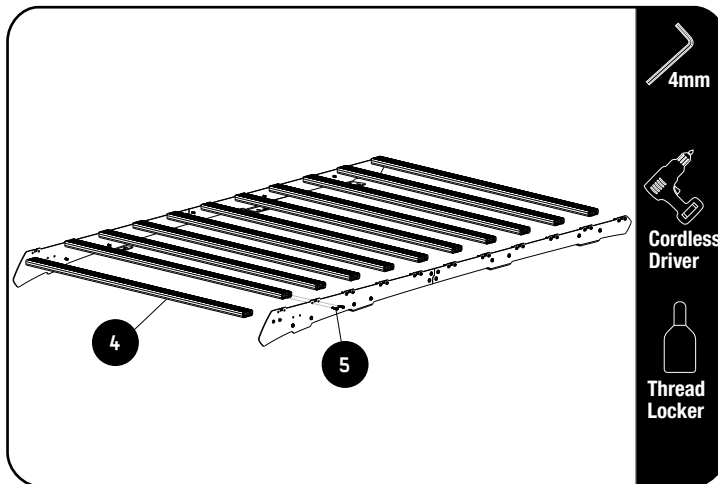

Fit 10 Slimsport Slats (Item 4) to the assembly 2.1 using M6 x 20 Button Head Screws (Item 5).



Note do not fit front slat.



Apply a little Thread Locker on screw threads before inserting.



Tightening Torque 8-10Nm / 5.9 ft lb - 7.38 ft lb. Take care when using a cordless driver.

3

PREPERATION

3.1

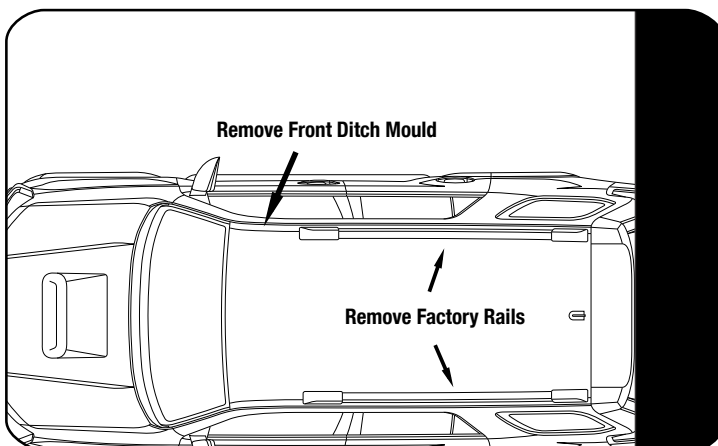

Remove both the factory rails from the vehicles roof.

See You tube for assistance.



Remove the left and right side ditch mould in front

3

PREPERATION

3.2

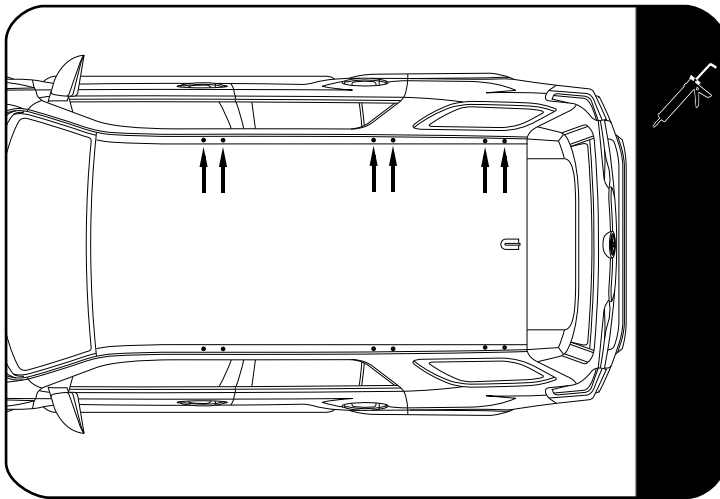

Use denatured alcohol and ensure the ditch is clean from any residue where the Front support Foot (Item 7) will be resting on the ditch as well as around all the factory mounting holes.

Place the 12 x 19 x 24 Spacers (Item 14) over each of the mounting points.

Fill each of the tube spacers with a suitable silicone sealant.

3.3

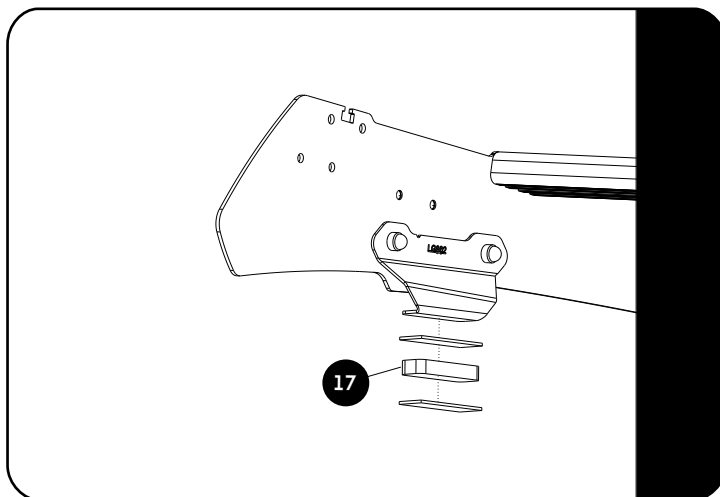

Remove the VHB backing from one side of the spacer. Align and adhere the spacer to the underside of the front support bracket.

3.4

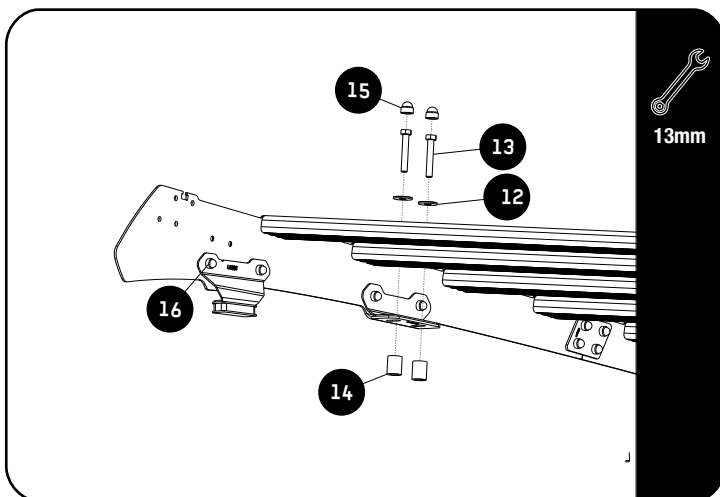

With the help of a friend lift the assembled rack over the vehicle roof and place it onto the spacers.

Start threading the rear bolts and washers (Item 13 & 12) into the roof inserts by a few threads. Do not fully tighten just yet. One bolt on the LH and one on the RH side

Lift the front of the rack slightly and remove the VHB backing from the under the front support spacer. Lower the front of the rack back down aligning the front support spacer in the middle of the ditch.

Insert the remaining 5 bolts and washers (Item 13 & 12) per side and tighten by hand before fully tightening all 12 bolts. Place M8 Nut caps (Item 15) over all the bolt heads.

4.1

STANDARD WIND FAIRING ASSEMBLY

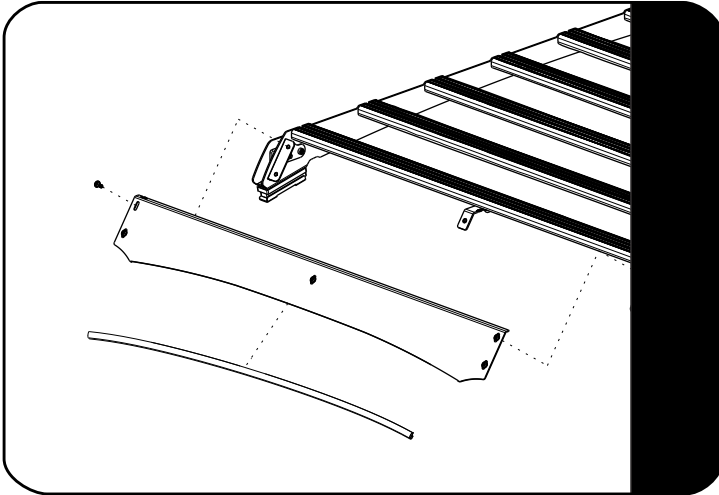

Refer to fitment guide RRAC324

4.2

LIGHT BAR WIND FAIRING ASSEMBLY

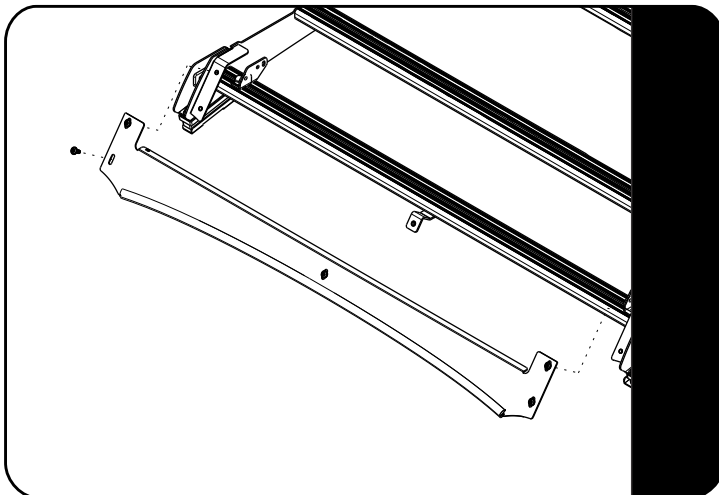

Refer to fitment guide RRAC325

5

COMPLETION

5.1

Congratulations! You did it. Take a step back and admire your work!



6

INSTALL OTHER VEHICLE AND RACK ACCESSORIES

Now's the time to visit your favorite Front Runner dealer in person or online.

IMPORTANT!

FRONT RUNNER RACK KITS OFTEN HAVE A HIGHER LOAD RATING THAN THE VEHICLES THEY ARE MOUNTED TO. PLEASE REFER TO YOUR SPECIFIC VEHICLE MANUFACTURER FOR A RECOMMENDED ROOF RATING. FRONT RUNNER CANNOT BE RESPONSIBLE FOR IMPROPER LOADING BEYOND THE VEHICLE MANUFACTURER'S STATED LOAD CAPACITY.

Be sure to tag us. We love to see our gear in action! #FrontRunnerOutfitters #BornToRoam

Share your adventures on: 