

# START HERE!

## READ ME FIRST

Don't be a hero and muscle through this installation without reading these fitting instructions first! Improper installation of this gear may void certain aspects of your warranty.

Before you begin, take a moment and open all your Front Runner Rack Kit boxes and gather the assembly instructions for the various components.

A complete kit will contain:

1. Front Runner Mounting System specific to your vehicle
2. Front Runner Rack Tray or Load Bar Slats

This document will guide you through the assembly of the Mounting System and assist you in fitting the Rack tray or Load Bars to your specific vehicle. Please refer to the next page for a list of all the components, quantities and tools required.

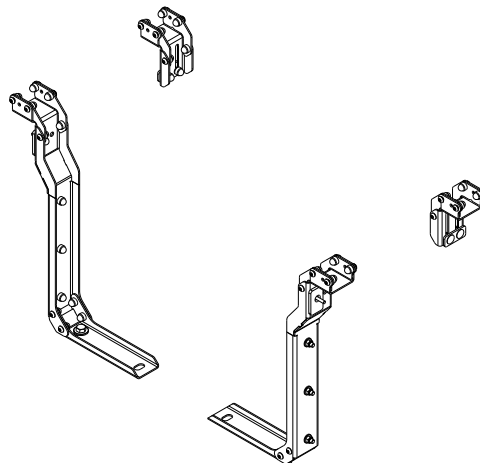

### IMPORTANT WARNING!

IT IS CRITICAL THAT ALL FRONT RUNNER PRODUCTS BE PROPERLY AND SECURELY ASSEMBLED AND ATTACHED TO YOUR VEHICLE. IMPROPER ATTACHMENT COULD RESULT IN AN AUTOMOBILE ACCIDENT, AND COULD CAUSE SERIOUS BODILY INJURY OR DEATH. YOU ARE RESPONSIBLE FOR ASSEMBLING AND SECURING ALL FRONT RUNNER PRODUCTS TO YOUR VEHICLE, CHECKING THE ATTACHMENTS PRIOR TO USE, AND PERIODICALLY INSPECTING THE PRODUCTS FOR ADJUSTMENT, WEAR AND DAMAGE. THEREFORE, YOU MUST READ AND UNDERSTAND ALL OF THE INSTRUCTIONS AND PRECAUTIONS SUPPLIED WITH YOUR FRONT RUNNER PRODUCT PRIOR TO INSTALLATION OR USE. IF YOU DO NOT UNDERSTAND ALL OF THE INSTRUCTIONS AND CAUTIONS, OR IF YOU HAVE NO MECHANICAL EXPERIENCE AND ARE NOT THOROUGHLY FAMILIAR WITH THE INSTALLATION PROCEDURES, YOU SHOULD HAVE THE PRODUCT INSTALLED BY A PROFESSIONAL INSTALLER OR OTHER QUALIFIED PERSONNEL.

**NOTE:** Front Runner will not be responsible for any damage caused by the failure to install the product according to these instructions.

Please call us if you have any questions about the installation of this product.



# 1 GET ORGANIZED

IN THE BOX		PBTT002
1	2 X	REAR BED STIFNER
2	2 X	REAR MAIN BRACKET
3	4 X	REAR BRACKET GUSSET
4	2 X	SPACERS
5	2 X	FRONT MAIN BRACKET
6	4 X	FRONT BRACKET GUSSET
7	2 X	STUD PLATE
8	16 X	M8 X 20 BUTTON HEAD SCREW
9	16 X	M8 X 16 BUTTON HEAD SCREW
10	2 X	M6 X 19 X 1 FLAT WASHER
11	2 X	M6 X 30 HEX HEAD BOLT
12	6 X	M8 X 20 HEX HEAD BOLT
13	6 X	M8 X 19 X 2 FLAT WASHER

IN THE BOX		PBTT002
14	42 X	M8 NYLOC NUT
15	2 X	M12 X 30 X 3 FLAT WASHER
16	2 X	7/16" - 20 X 1.25" HEX BOLT
17	4 X	M8 X 25 CARRIAGE BOLT
18	4 X	M8 X 16 X 1.6 FLAT WASHER
19	44 X	M8 NUT CAP

**TOOLS NEEDED**

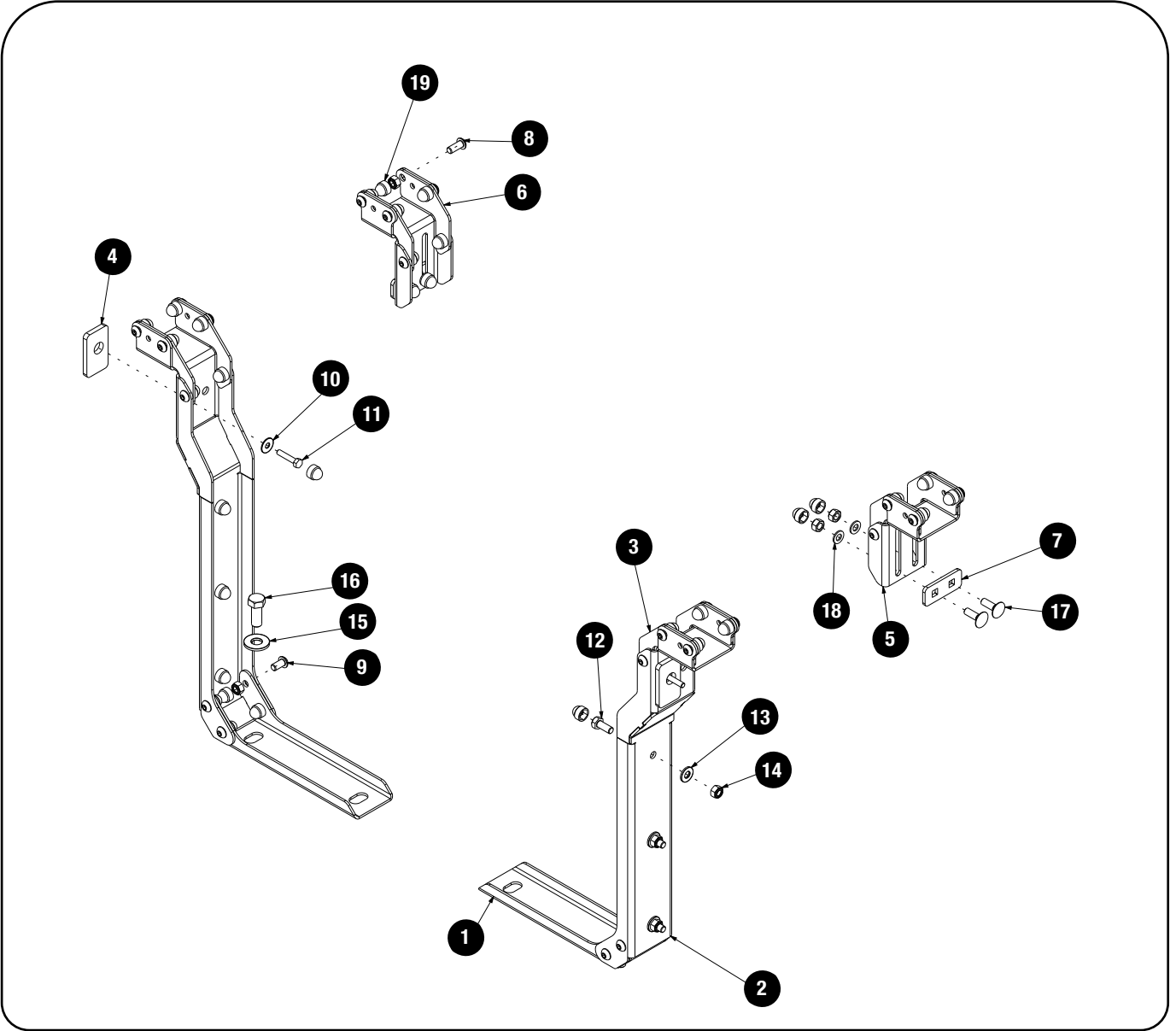



# 1 GET ORGANIZED

IN THE BOX		PBRA001
1	4 X	PRO BED RACK LEG
2	2 X	PRO BED RACK REAR BRACE
3	2 X	PRO BED RACK RH REAR WING BRACKET
4	2 X	PRO BED RACK TOP TRUSS
5	1 X	PRO BED RACK RH FRONT DIAGONAL BRACE
6	1 X	PRO BED RACK LH FRONT DIAGONAL BRACE
7	12 X	M6 x 16 BUTTON HEAD SCREW
8	22 X	M6 NYLOC NUT
9	22 X	M6 NUT CAP
10	16 X	M8 x 20 BUTTON HEAD SCREW
11	16 X	M8 x 19 x 2 FLAT WASHER
12	16 X	M8 NYLOC NUT
13	16 X	M8 NUT CAP

IN THE BOX		PBRA001
14	6 X	M6 x 12 BUTTON HEAD SCREW
15	2 X	FRONT HORIZONTAL BRACE
16	1 X	FRONT CENTER BRACE
17	4 X	M6 x 20 BUTTON HEAD SCREW
18	8 X	M6 x 12 x 1 FLAT WASHER
19	24 X	M6 x 25 THREAD FORMING SCREW
20	1 X	T30 6" TORX BIT

**TOOLS NEEDED**

13mm  
10mm

5mm  
4mm

Torx  
T30  
T40  
T55

Oil or  
Anti Seize

X 2

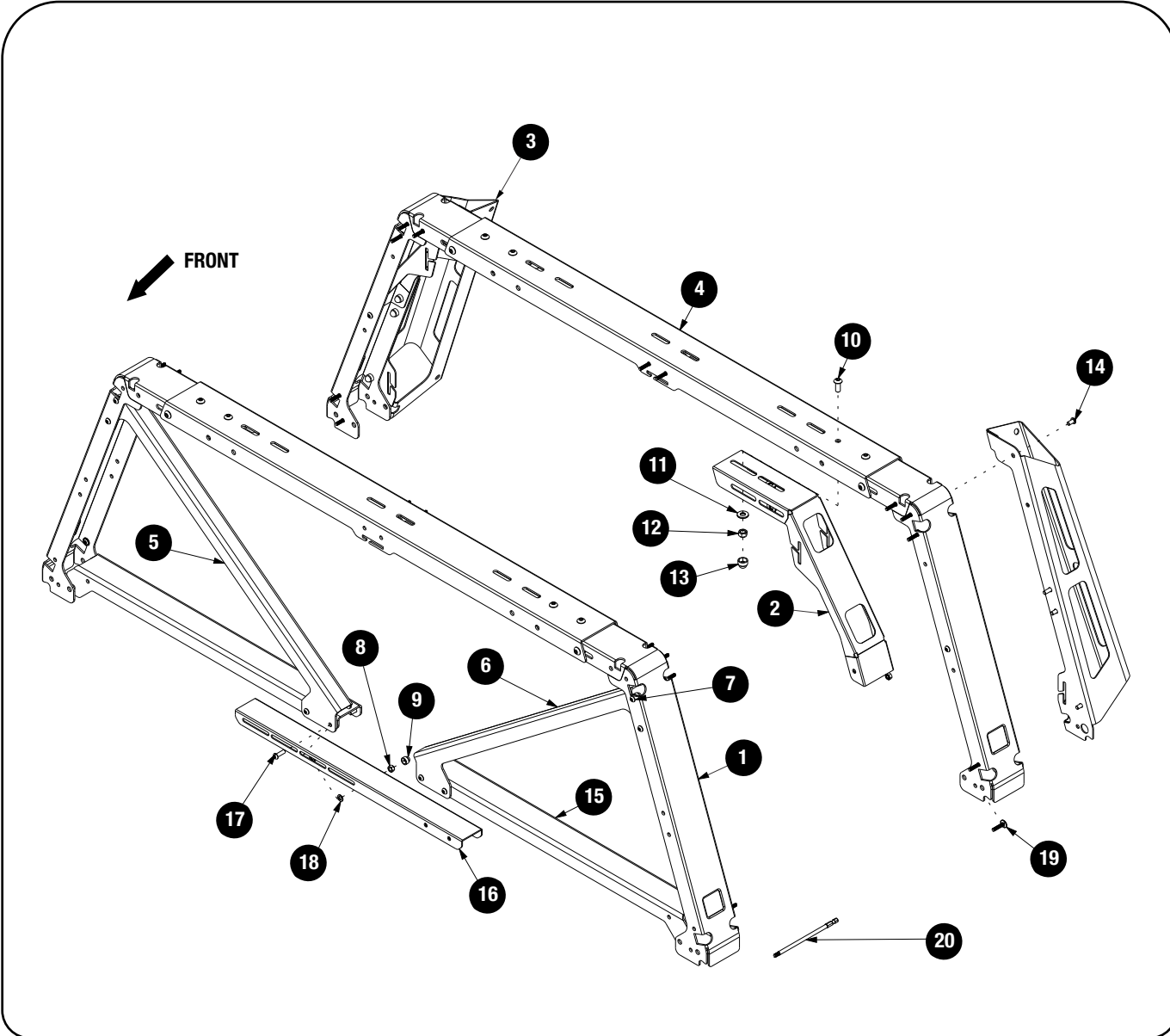



1

### GET ORGANIZED

#### IN THE BOX

PBAL\_1250

1	2 X	TOP EXTRUSION
2	1 X	TOP MIDDLE EXTRUSION
3	2 X	BOTTOM EXTRUSION
4	2 X	1250mm PSA STRIP PE60

#### TOOLS NEEDED



Friend

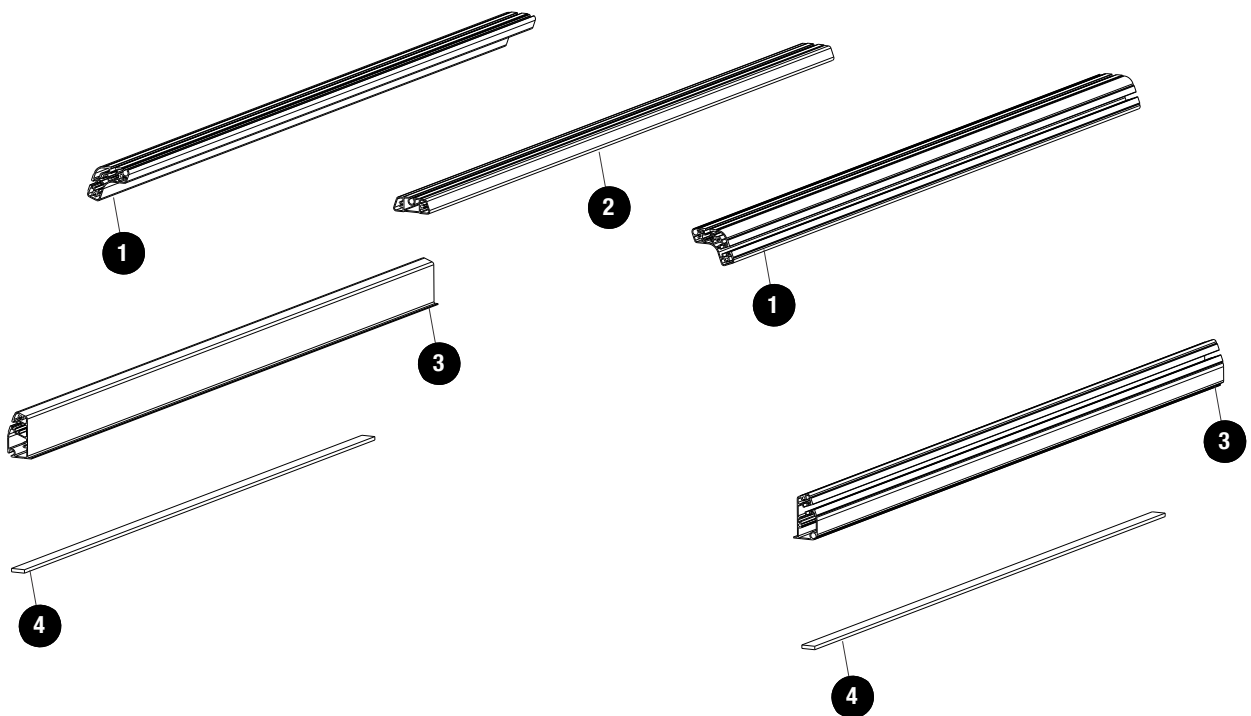

**2**

**FIT AND SECURE**

2.1

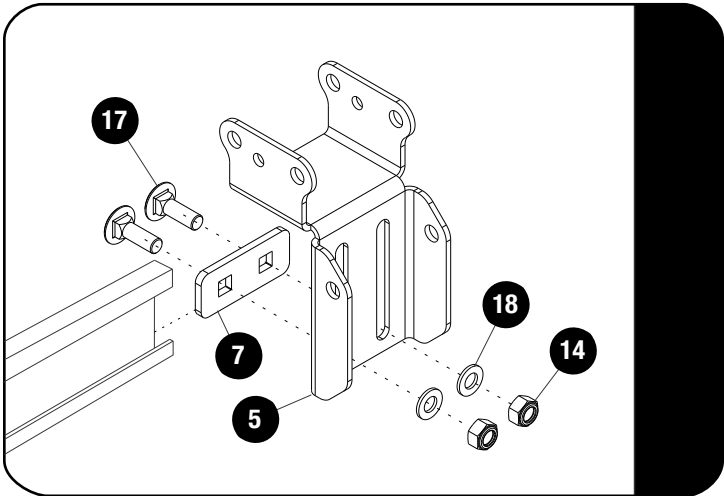

Remove the factory rail end caps. Slide a channel plate (Item 7) into both the LH & RH cargo rail

Loosly assemble the Front Mount Brackets (item 5) using the carriage bolts, M8x16x1.6 Flat washer and M8 Nyloc Nut (Item 17,18 & 14).

Do this on both the LH and RH side  
**DO NOT FULLY TIGHTEN**

2.2

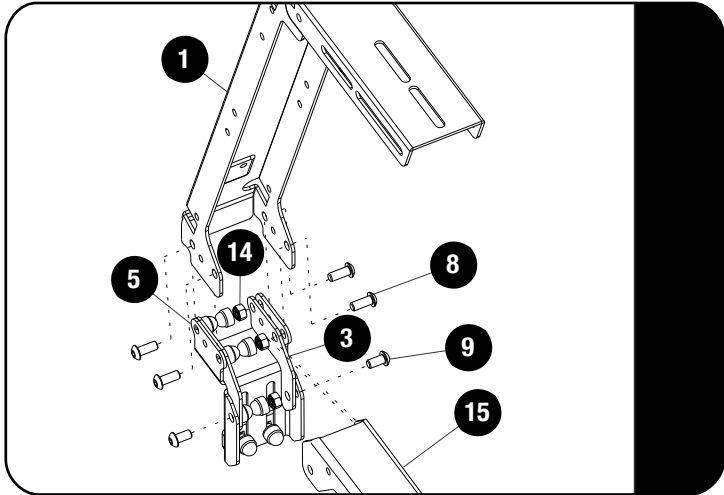

Assemble the Pro Bed Leg (Item 1) to the Front Channel Mount (Item 5) and the Front Gusset (Item 3) using M8x20 Button Head screws and M8 Nyloc Nuts (Item 8 & 14) as shown and M8x16 Button Head screws and M8 Nyloc Nuts (Item 9 & 14).

Do this on both the LH and RH side  
**DO NOT FULLY TIGHTEN**

2.3

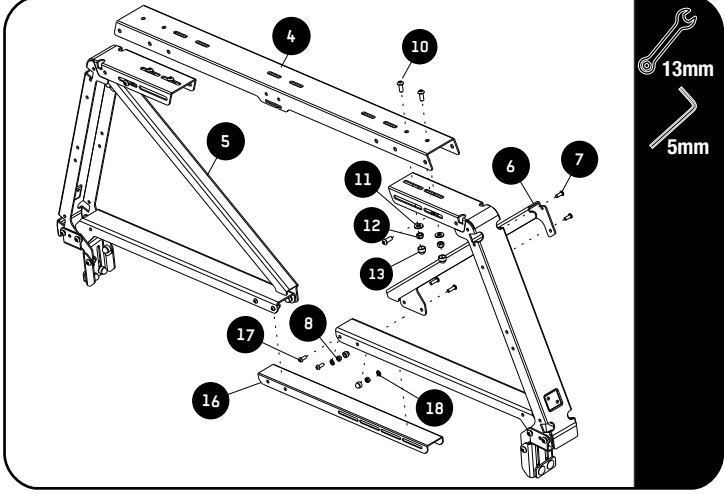

Assemble the Front Diagonal and Horizontal Brace parts as shown (Item 4,5 & 6) to the legs fitted in 2.2 using the M8x20 Button head screws, M8x19x2 Flat washer and M8 Nyloc Nut (Item 10,11 & 12).

**FULLY TIGHTEN.**

Use the M6x20 Button head Screws, M6x12x1 Flat washer and M6 Nyloc Nut (Item 8,17 & 18) to fit the Front Center Brace to the LH and RH Front Horizontal Braces (Item 16).

**DO NOT FULLY TIGHTEN**

2.4

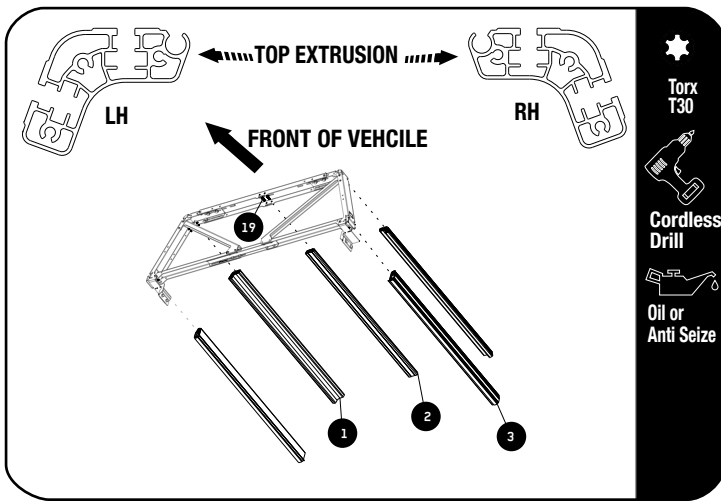

Slide the front leg and truss assembly backward to allow access for securing extrusions.

**Take note of extrusion orientation !**

Using the supplied T30 6" torx bit and a cordless driver fit the extrusion using the M6x25 thread forming screws (Item 19). Use a slow and constant speed when using the cordless driver.

**Use a little anti seize or oil on screw threads before inserting. Note these are Thread Forming Screws.**

When complete slide assembly forward in the cargo rails giving room for rear legs to be assembled.

**Tightening Torque 25Nm / 18.4 ft lbs**

2.5

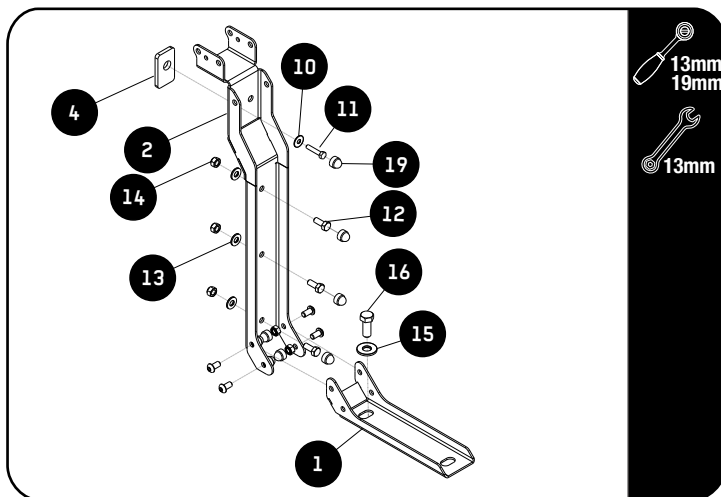

Remove the two rear factory bed bolts and two factory D rings using a T55 and T40.

Position the Bed Stiffener against the rear bed pillars aligning the two factory bed holes. Mark the 3 hole positions on both the LH and RH bed pillars.

Remove the rear tail lights (check youtube for videos to assist).

Drill pilot holes on the 3 marked holes on both bed pillars using a 4mm drill. Open hole using a 9mm drill and apply anti rust.

Place the 6mm spacer (Item 4) over the top hole before securing the bed stiffener mount to the bed pillars using M8x20 hex bolts, M8x19x2 washers and M8 nyloc nuts. Do not fully tighten yet. Secure the base to the bed using the T55 bolt removed earlier and 7/16" - 20 X 1.25" Hex Bolt (Item 16).

Fully tighten all five bolts on both the LH and

2.6

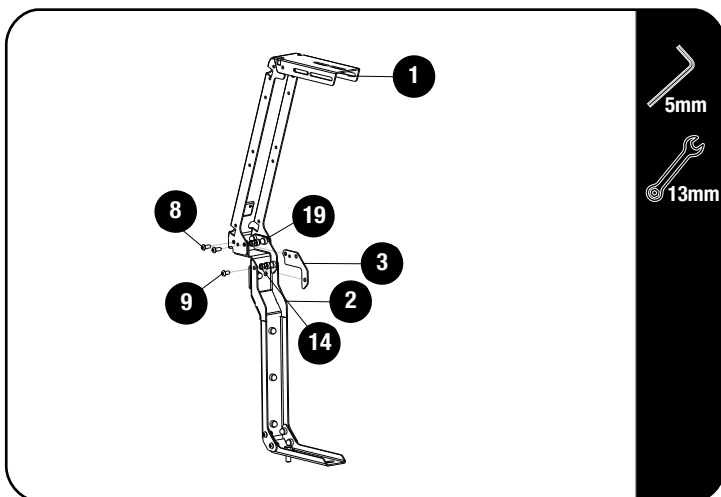

Assemble the Pro Bed Rack Leg (Item 1) to the rear top main bracket (Item 2) using the rear gusset (item 3) and M8x16 Button head screw and M8 nyloc Nut as shown.

Assemble the M8x20 Button head screw and M8 Nyloc Nut (Item 8&9) and fully tighten all the bolts.

Place the M8 Nut caps (Item 19) where needed.

**Tightening Torque:**  
M8 : 15-20Nm / 11.06 ft lb - 14.75 ft lb

2

**FIT AND SECURE**

2.7

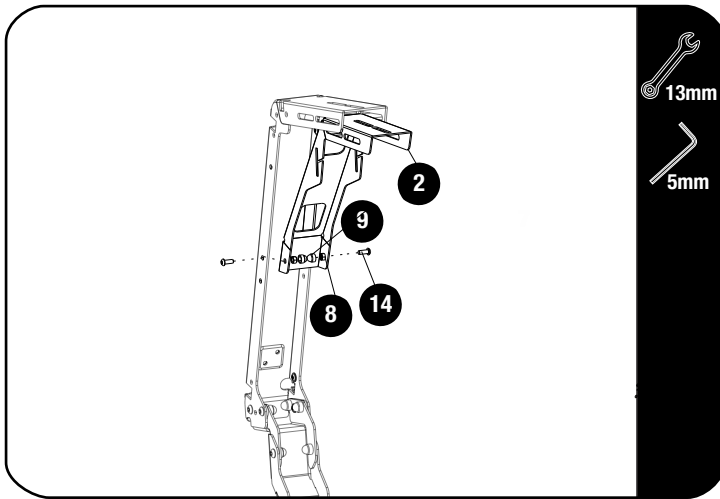

Fit the Rear Brace (Item 2) using the M6x12 button head screws and M6 Nyloc nuts (Item 14 & 8). Fully tighten and place M6 Nut caps (Item 9) on the M6 Nyloc Nuts.



**Tightening Torque:**

M6 : 8-10Nm / 5.9 ft lb - 7.38 ft lb

2.8

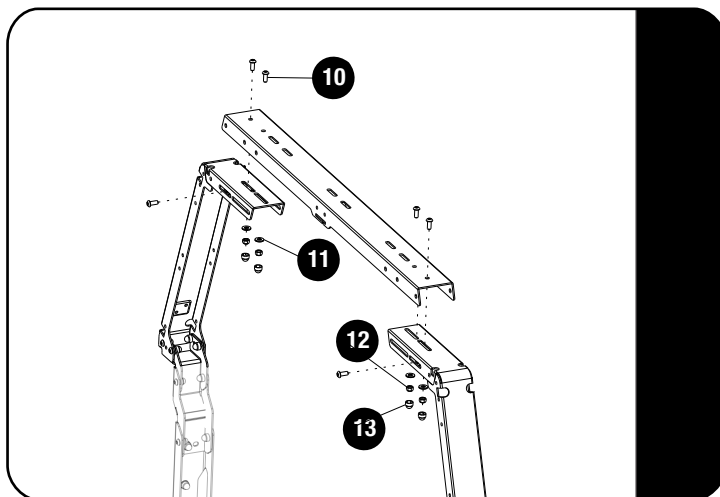

Loosely assemble the rear top truss using the M8x20 Button head screws, M8x19x2 Flat washer and M8 Nyloc Nuts (Item 10,11&12). Fully tighten the M8 Button Heads and place M8 Nut Caps on the M8 Nyloc Nuts (Item 13).



**Tightening Torque:**

M8 : 15-20Nm / 11.06 ft lb - 14.75 ft lb

2.9

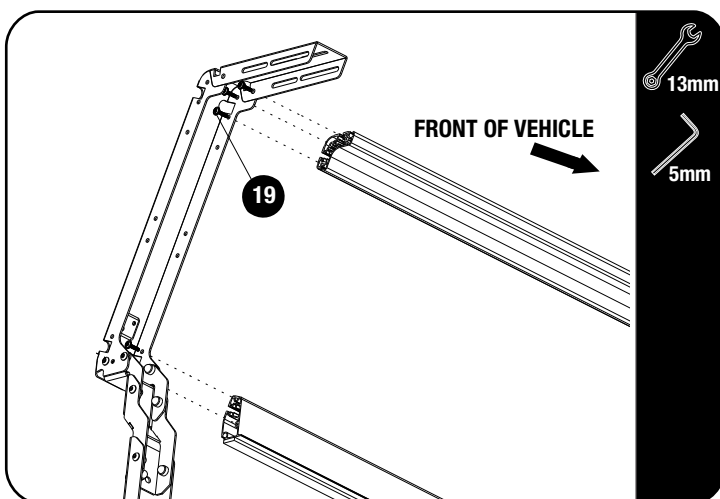

Pull the front leg / truss / extrusion assembly toward the rear legs. Attach the rear leg assembly to the Extrusions using the M6x25 thread forming screws (Item 19) and a cordless driver. The front assembly will be pulled back into its final position while fully tightening these screws.



Use a little anti seize or oil on screw threads before inserting. Note these are Thread Forming Screws.



Tightening Torque 25Nm / 18.4 ft lbs

2

FIT AND SECURE

2.10

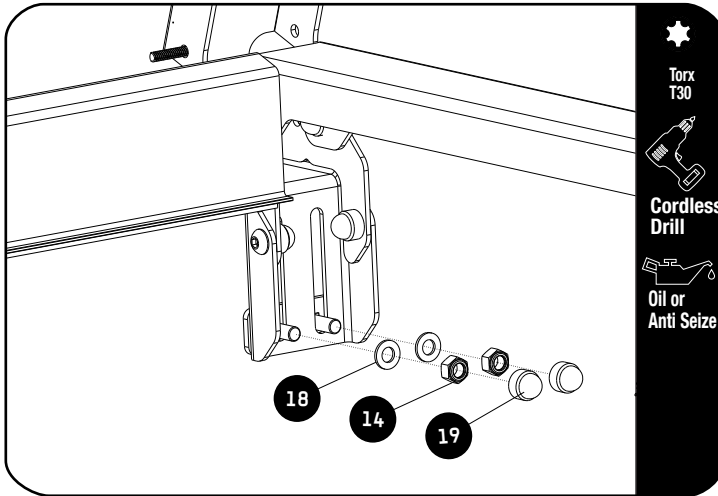

With the Load Bed rack in Position fully tighten the bracket fitted in 2.1. Place M8 Nut caps (Item 19) onto the M8 Nyloc nuts (Item 14 ).



Tightening Torque:

M8 : 15-20Nm / 11.06 ft lb - 14.75 ft lb

2.11

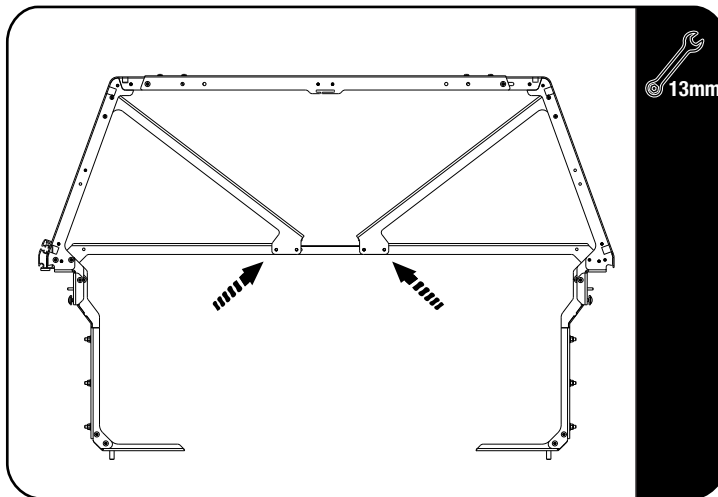

Using clamps and a spirit level clamp the spirit level to the inside of the Front Center Brace and Tighten the M6x20 Button head screws and M6 Nyloc Nuts fitted in 2.3. Place M6 Nut caps on the M6 Nyloc Nuts.

2.12

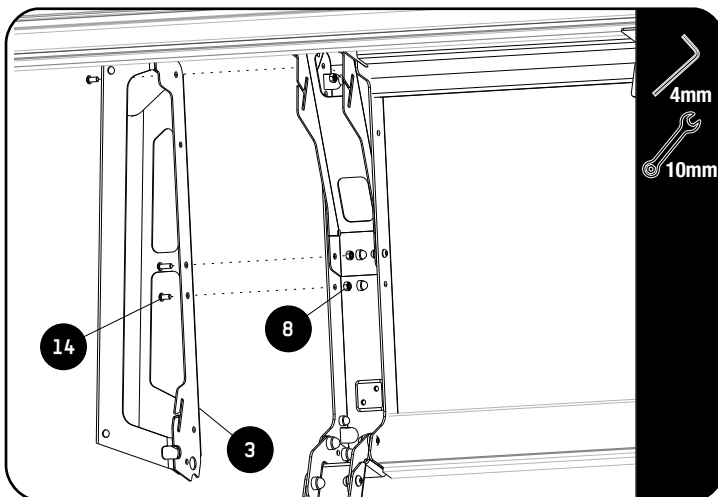

Assemble the Rear Wing Brackets (Item 3) using the M6x12 Button head screws and M6 Nyloc Nuts (Item 14 & 8).

Place the M6 Nut caps (Item 9) over the nyloc nut

2

## FIT AND SECURE

2.13

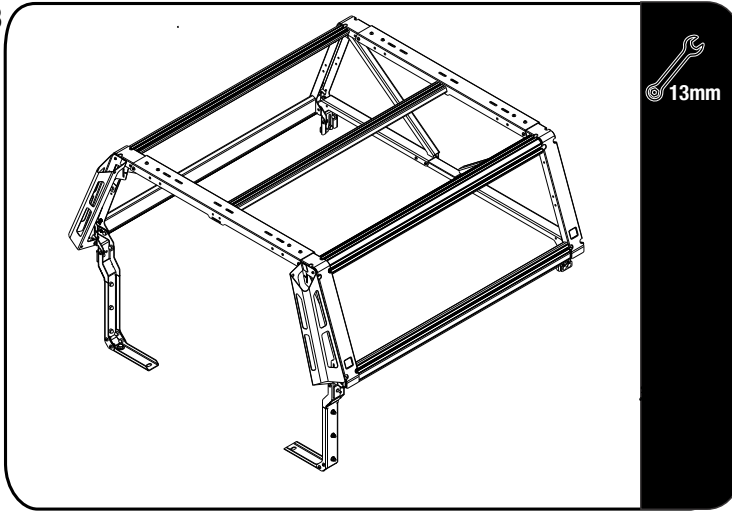

Fully tighten all the bolts and nuts and place nut caps where needed.

6

## COMPLETION

6.1

Congratulations! You did it. Take a step back and admire your work!



7

## INSTALL OTHER VEHICLE AND RACK ACCESSORIES

Now's the time to visit your favorite Front Runner dealer in person or online.

### IMPORTANT!

FRONT RUNNER RACK KITS OFTEN HAVE A HIGHER LOAD RATING THAN THE VEHICLES THEY ARE MOUNTED TO. PLEASE REFER TO YOUR SPECIFIC VEHICLE MANUFACTURER FOR A RECOMMENDED ROOF RATING. FRONT RUNNER CANNOT BE RESPONSIBLE FOR IMPROPER LOADING BEYOND THE VEHICLE MANUFACTURER'S STATED LOAD CAPACITY.

Be sure to tag us. We love to see our gear in action! #FrontRunnerOutfitters #BornToRoam

Share your adventures on: 