

START HERE!

READ ME FIRST

Don't be a hero and muscle through this installation without reading these fitting instructions first! Improper installation of this gear may void certain aspects of your warranty.

Before you begin, take a moment and open all your Front Runner rack kit boxes and gather the assembly instructions for the various components.

A complete kit will contain:

1. A Front Runner SlimSport Kit

This document will guide you through the assembly of the mounting system and assist you in fitting the roof rack tray or load bars to your specific vehicle.

Please refer to the next page for a list of all the components, quantities and tools required.

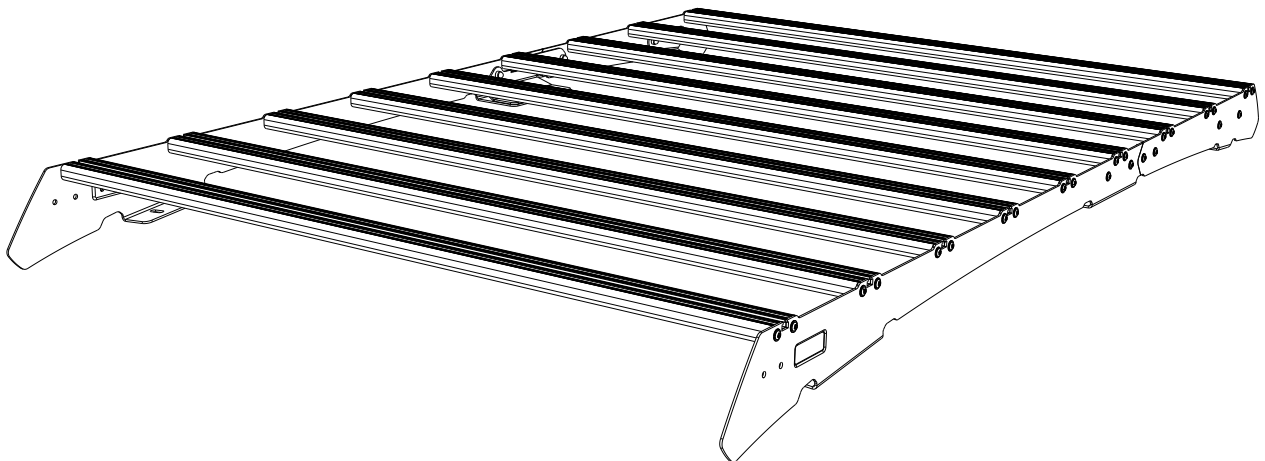

IMPORTANT WARNING!

IT IS CRITICAL THAT ALL FRONT RUNNER PRODUCTS BE PROPERLY AND SECURELY ASSEMBLED AND ATTACHED TO YOUR VEHICLE. IMPROPER ATTACHMENT COULD RESULT IN AN AUTOMOBILE ACCIDENT, AND COULD CAUSE SERIOUS BODILY INJURY OR DEATH. YOU ARE RESPONSIBLE FOR ASSEMBLING AND SECURING ALL FRONT RUNNER PRODUCTS TO YOUR VEHICLE, CHECKING THE ATTACHMENTS PRIOR TO USE, AND PERIODICALLY INSPECTING THE PRODUCTS FOR ADJUSTMENT, WEAR AND DAMAGE. THEREFORE, YOU MUST READ AND UNDERSTAND ALL OF THE INSTRUCTIONS AND PRECAUTIONS SUPPLIED WITH YOUR FRONT RUNNER PRODUCT PRIOR TO INSTALLATION OR USE. IF YOU DO NOT UNDERSTAND ALL OF THE INSTRUCTIONS AND CAUTIONS, OR IF YOU HAVE NO MECHANICAL EXPERIENCE AND ARE NOT THOROUGHLY FAMILIAR WITH THE INSTALLATION PROCEDURES, YOU SHOULD HAVE THE PRODUCT INSTALLED BY A PROFESSIONAL INSTALLER OR OTHER QUALIFIED PERSONNEL.

NOTE: Front Runner will not be responsible for any damage caused by the failure to install the product according to these instructions.

Please call us if you have any questions about the installation of this product.



1 GET ORGANIZED

IN THE BOX

1	2 X	Front Foot Rail 1LH & 1RH
2	2 X	Middle Stiffener Plate 1LH & 1RH
3	2 X	Rear Stiffener Plate 1LH & 1RH
4	9 X	Slimsport Slat
5	36 X	M6x20 Button Head Screw
6	12 X	M6x16 Button Head Screw
7	20 X	M6 Nyloc Nut
8	22 X	M6 Nut Cap
9	10 X	19x24 Spacer
10	10 X	M6x50 Hex Bolt
11	18 X	M6x20x2 Flat Washer
12	3 X	M6 Jack Nut
13	2 X	M6x30 Button Head Bolt
14	1 X	Jack Nut Tool
15	8 X	Push In Rivet
16	2 X	Rear Foot Rail 1LH & 1RH
17	6 X	Panoramic Roof Plugs 12mm

TOOLS NEEDED

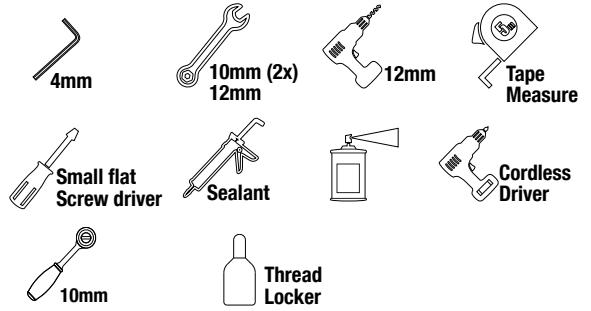
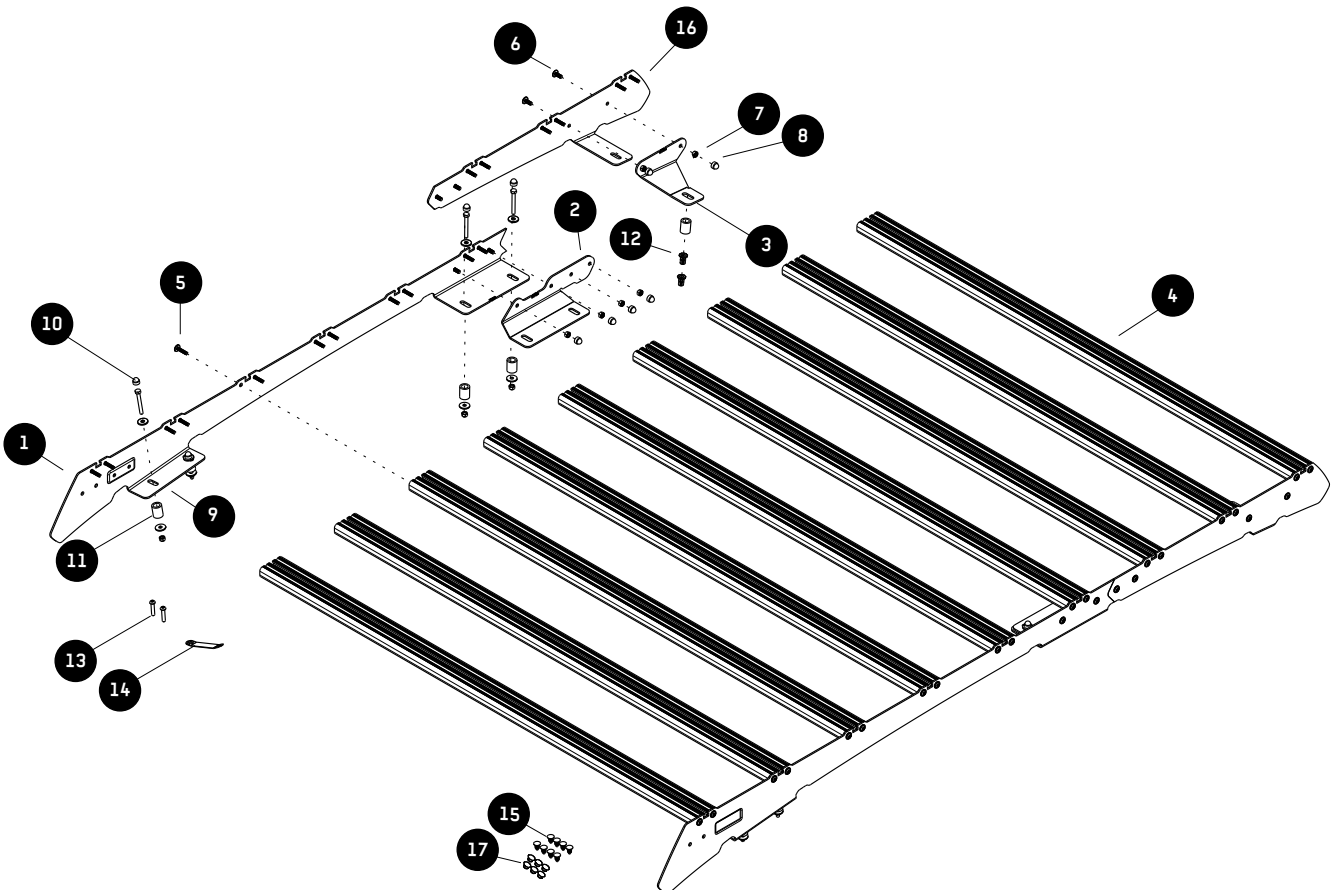
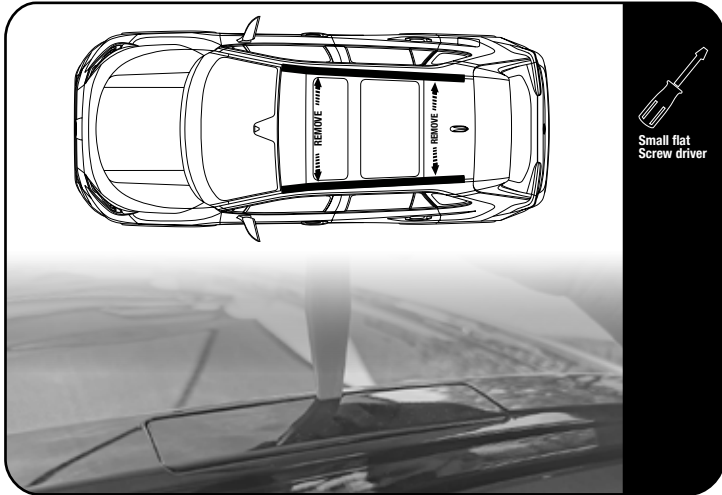

FIGURE 1.1



2.1



REMOVE FACTORY MOUNTED RAILS

Depending on model and spec, your vehicle will either have raised or flush factory rails. For flush rails remove the front and rear covers from the vehicle's roof rails using a flat screw driver or suitable panel tool.

2.2

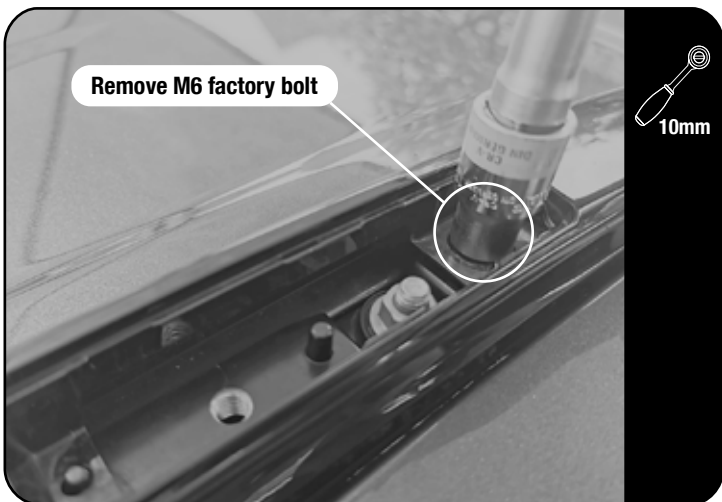

Loosen the M6 factory bolts shown in 2.2. Lift the rails off of the roof by unclipping in sequence from back to front of the vehicle.

2.3



For both raised and flush rails the vehicles headliner will need to be dropped.

Look online for videos to assist.

Locate and remove the nuts securing the rails/mount plates to the roof of the vehicle (4 per side).

2.4

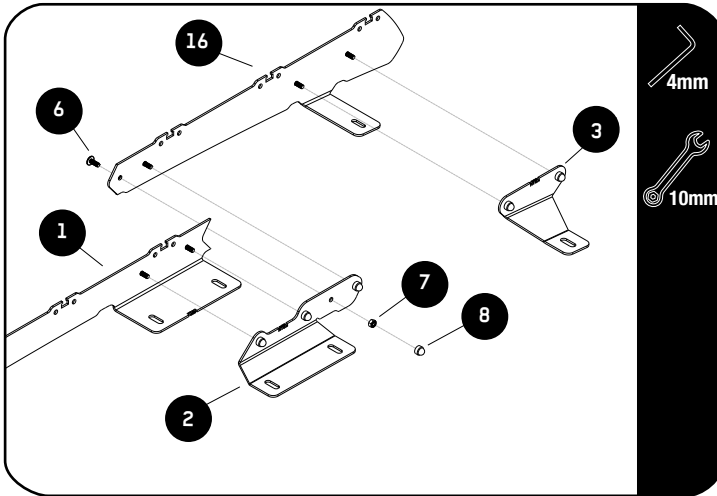

Join the Front LH and Rear LH Foot Rails (Item 1 & 16) with the Middle Stiffener Plate provided (Item 2) using M6 x 16 Button Head Bolts and M6 Nyloc Nuts (Items 6 & 7).

Secure the Rear Stiffener Plate to the LH Assembly using M6 x 16 Button Head Bolts and M6 Nyloc Nuts (Items 6 & 7).

Repeat this for the Front RH and Rear RH Foot Rail.

Place M6 Nut Caps (Item 8) over all Nyloc Nuts.

2.5

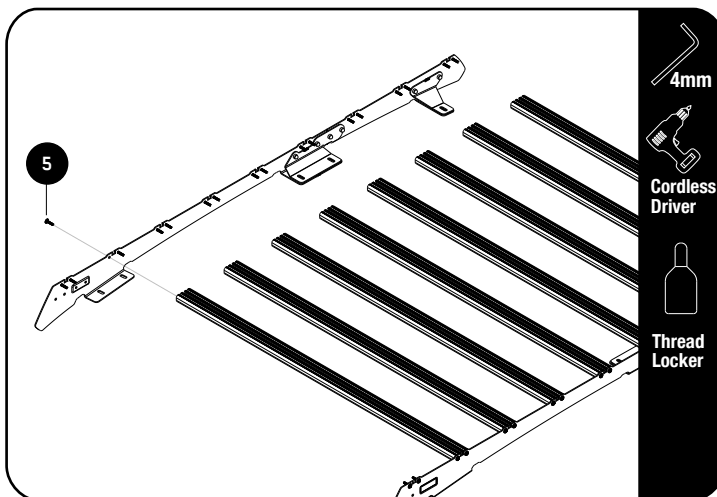

NOTE: Do not fit the front slat yet.



Apply a little Thread Locker on screw threads before inserting.



Assemble 8 Slimsport slats (Item 4) to the foot rails using M6 x 20 Button Head Screws (Item 5). Starting from the back to the front, do not fit the front Slat yet.



Tightening Torque 8-10Nm / 5.9 ft lb - 7.38 ft lb. Take care when using a cordless driver.

2.6

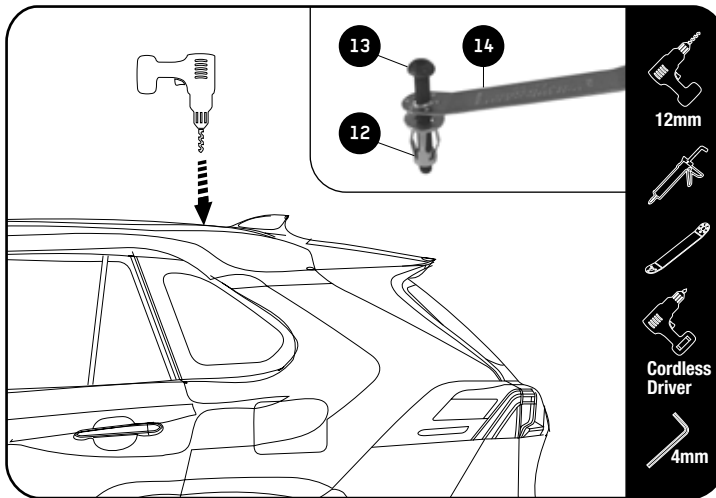

Open the rear factory hole on the left and right side to suit the Jack nut diameter of 12mm (item 12)

Insert an M6 Button Head Bolt (Item 13) into the one side of the Installer Wrench (Item 14), loosely fit a Jack Nut (Item 12) to the Button Head Bolt as shown.

Clean and apply a small bead of clear silicone around the drilled hole and place the Jacknut into the hole.

Using a battery powered driver and a 4mm Allen Key Bit, set the Jack Nut into the hole while holding onto the handle of the Installer Wrench.

Remove the bolt once completed. Repeat this process on both rear holes 1 on the left and 1 on the right side of the vehicle.

Make sure that the Jack Nut has pulled up all the way to the inside skin of the roof panel.

2.7

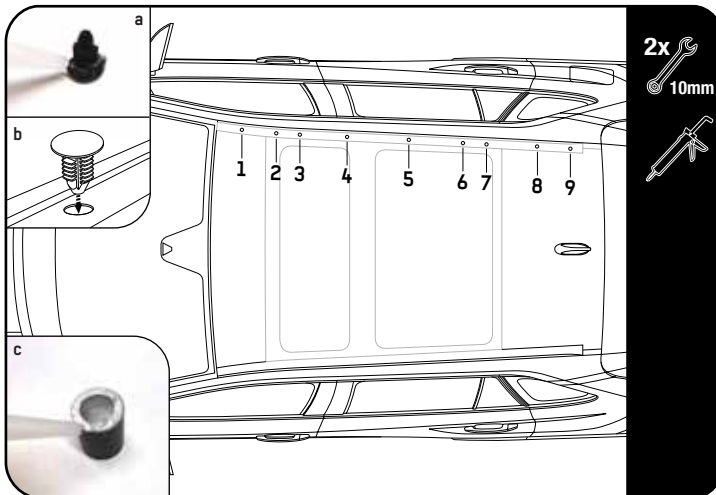

Seal holes 1, 4, 5 & 8 using the push in rivets (Item 15).

For vehicle versions with a panoramic roof use the 12mm Plugs (Item 17) as mentioned above.

Apply a small amount of silicone around the edge of the rivet before inserting into the holes (refer to figure 2.7 a & b.

Wipe away any excess silicone.

Apply silicone along the edge of the spacers as shown in figure 2.7 c.

Center the spacers (item 9) over holes 2, 3, 6, 7 & 9.

Place some more silicone inside each spacer.

2.8

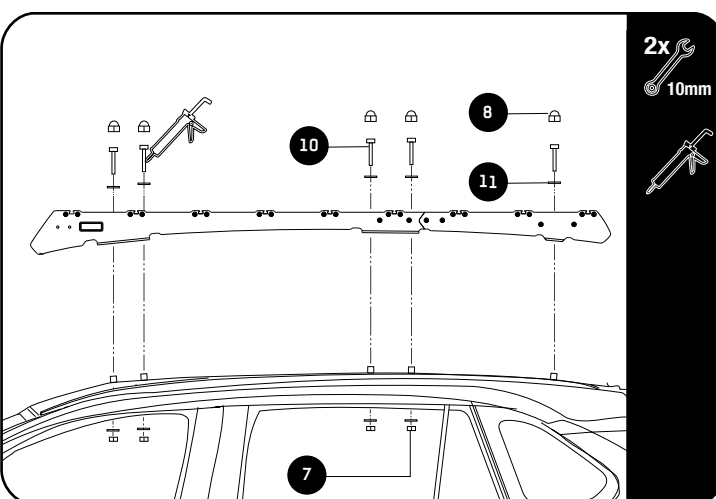

Position the rack over the roof aligning the mounting holes over the spacers.

With a small bead of silicone on the thread fasten M6x50 Hex Bolts at the rear into the Jack nuts along with the M6x20x2 flat washers and the M6 Nut caps. (item 7, 8, 10 & 11). Do not fully tighten.

Fasten the remaining bolts into the mounting holes.

Make sure each bolt has a small bead of clear silicone applied to the thread before fastening.

Align and center the rack on the vehicle. Fully tighten all fasteners.

Re-fit the vehicle's Roof Lining.

2.9.1

STANDARD WIND FAIRING ASSEMBLY

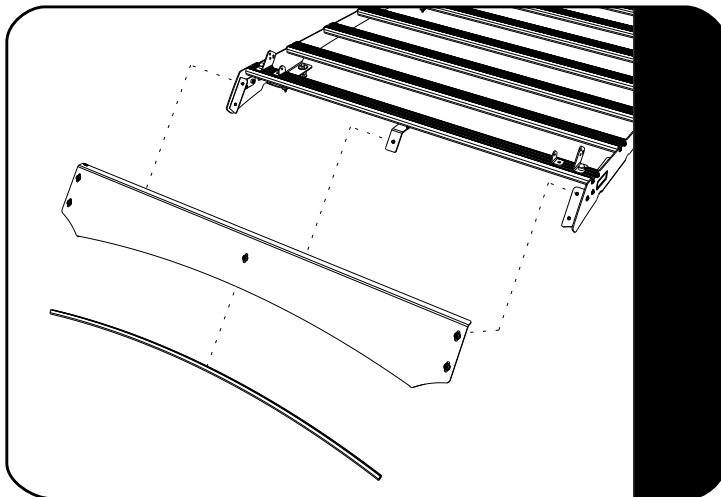

Refer to fitment guide RRAC238

2.9.2

LIGHT BAR WIND FAIRING ASSEMBLY

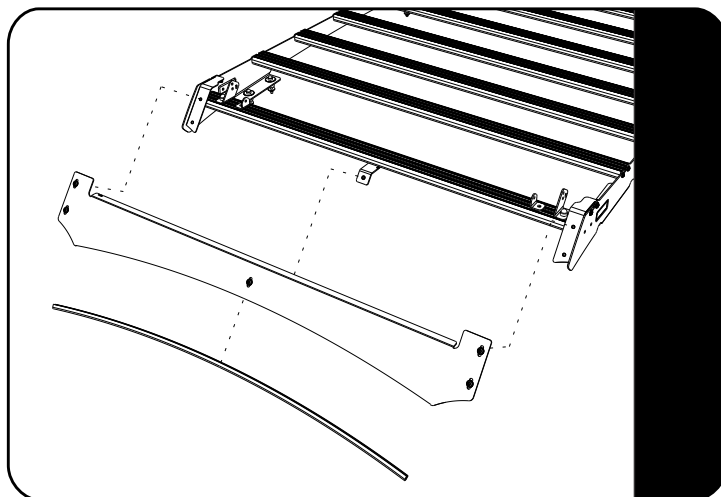

Refer to fitment guide RRAC220

3

COMPLETION

3.1

Congratulations! You did it. Take a step back and admire your work!



4

INSTALL OTHER VEHICLE AND RACK ACCESSORIES

Now's the time to visit your favorite Front Runner dealer in person or online.

IMPORTANT!

FRONT RUNNER RACK KITS OFTEN HAVE A HIGHER LOAD RATING THAN THE VEHICLES THEY ARE MOUNTED TO. PLEASE REFER TO YOUR SPECIFIC VEHICLE MANUFACTURER FOR A RECOMMENDED ROOF RATING. FRONT RUNNER CANNOT BE RESPONSIBLE FOR IMPROPER LOADING BEYOND THE VEHICLE MANUFACTURER'S STATED LOAD CAPACITY.

Be sure to tag us. We love to see our gear in action! #FrontRunnerOutfitters #BornToRoam

Share your adventures on: 