

READ ME !



Thank you for purchasing a Front Runner Ineos Grenadier Storage System.

Before you start, take a moment to familiarize yourself with the Fitting Instructions and the components received.

Refer to Page 2 for a list of all the components, quantities and tools required.

IMPORTANT WARNING! 

IT IS CRITICAL THAT ALL FRONT RUNNER PRODUCTS BE PROPERLY AND SECURELY ASSEMBLED AND ATTACHED TO YOUR VEHICLE. IMPROPER ATTACHMENT COULD RESULT IN AN AUTOMOBILE ACCIDENT, AND COULD CAUSE SERIOUS BODILY INJURY OR DEATH. YOU ARE RESPONSIBLE FOR ASSEMBLING AND SECURING ALL FRONT RUNNER PRODUCTS TO YOUR VEHICLE. CHECKING THE ATTACHMENTS PRIOR TO USE, AND PERIODICALLY INSPECTING THE PRODUCTS FOR ADJUSTMENT, WEAR AND DAMAGE. THEREFORE YOU MUST READ AND UNDERSTAND ALL OF THE INSTRUCTIONS AND PRECAUTIONS SUPPLIED WITH YOUR FRONT RUNNER PRODUCT PRIOR TO INSTALLATION OR USE. IF YOU DO NOT UNDERSTAND ALL OF THE INSTRUCTIONS AND CAUTIONS, OR IF YOU HAVE NO MECHANICAL EXPERIENCE AND ARE NOT THOROUGHLY FAMILIAR WITH THE INSTALLATION PROCEDURES, YOU SHOULD HAVE THE PRODUCT INSTALLED BY A PROFESSIONAL INSTALLER OR OTHER QUALIFIED PERSONNEL.

1

GET ORGANIZED

IN THE BOX

1	2 X	Corner
2	2 X	Front Extrusion 1074.6mm Long
3	2 X	Front Leg Extrusion 249.3mm Long
4	2 X	Side Extrusion 724.6mm Long
5	1 X	Top Back Extrusion 1129.6mm Long
6	3 X	Back Leg Extrusion 224.6mm Long
7	1 X	Bottom Back Extrusion 999.6mm Long
8	2 X	Deck
9	8 X	Corner Bracket
10	8 X	Middle Bracket
11	16 X	M6 x 25 Countersink Bolt
12	2 X	Front Mounting Bracket (1 LH & 1 RH)
13	2 X	Back Mounting Bracket (1 LH & 1 RH)
14	4 X	Spacer 19 x 22
15	46 X	M6 Thin Nut
16	46 X	M6 x 8 Button Head Bolt
17	4 X	M8 x 16 x1.6 Flat Washer
18	4 X	M8 x 45 Button Head Bolt
19	1 X	Completion Deck 01
20	1 X	Completion Deck 02
21	1 X	Completion Deck 03
22	2 X	Back Completion Deck Support (1 LH & 1 RH)

IN THE BOX

23	3 X	Mid Completion Deck Support
24	1 X	Front Completion Deck Support LH
25	1 X	Front Completion Deck Support RH
26	8 X	M6 x 20 Countersink Bolt
27	4 X	Joiner Plate
28	8 X	Spring Assembly
29	36 X	M6 x 12 Hex Bolt
30	36 X	M6 Nyloc Nut
31	36 X	M6 Nut Cap
32	6 X	Corner Gusset

TOOLS NEEDED

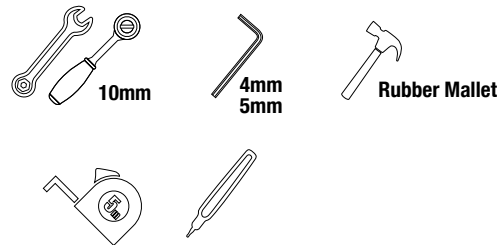
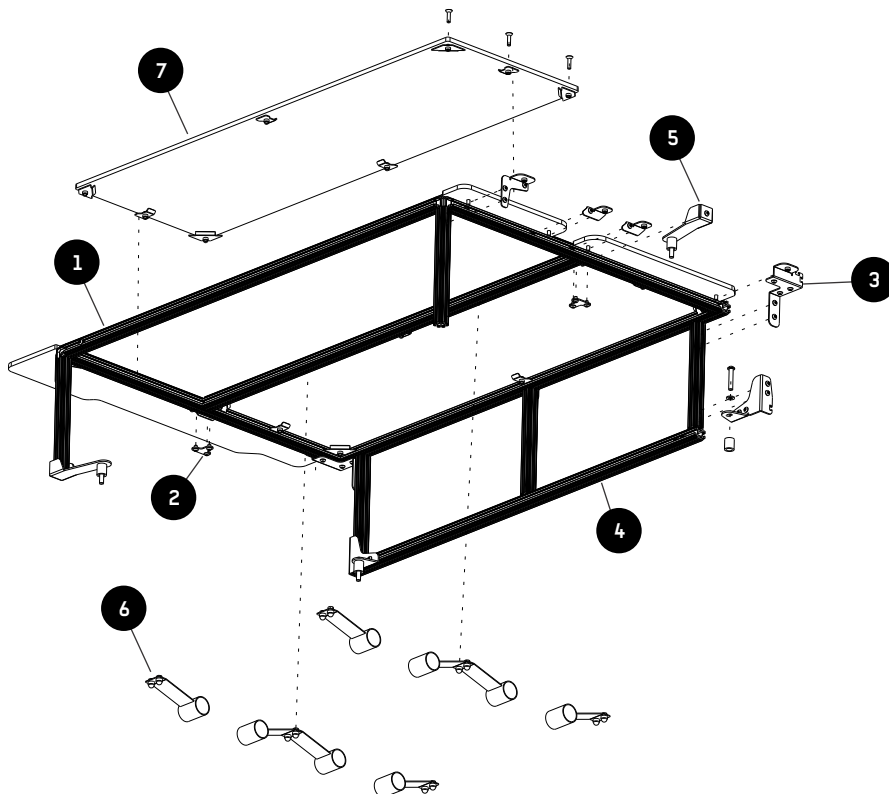

FIGURE 1.1

NOTE: This Unit is broken down into Sub-Assemblies and is marked accordingly.



2

SUB-ASSEMBLY 1

IN THE BOX

1	2 X	Corner
2	2 X	Front Extrusion 1074.6mm Long
3	2 X	Front Leg Extrusion 249.3mm Long
4	2 X	Side Extrusion 724.6mm Long
5	1 X	Top Back Extrusion 1129.6mm Long
29	12 X	M6 x 12 Hex Bolt

TOOLS NEEDED



FIGURE 2.1

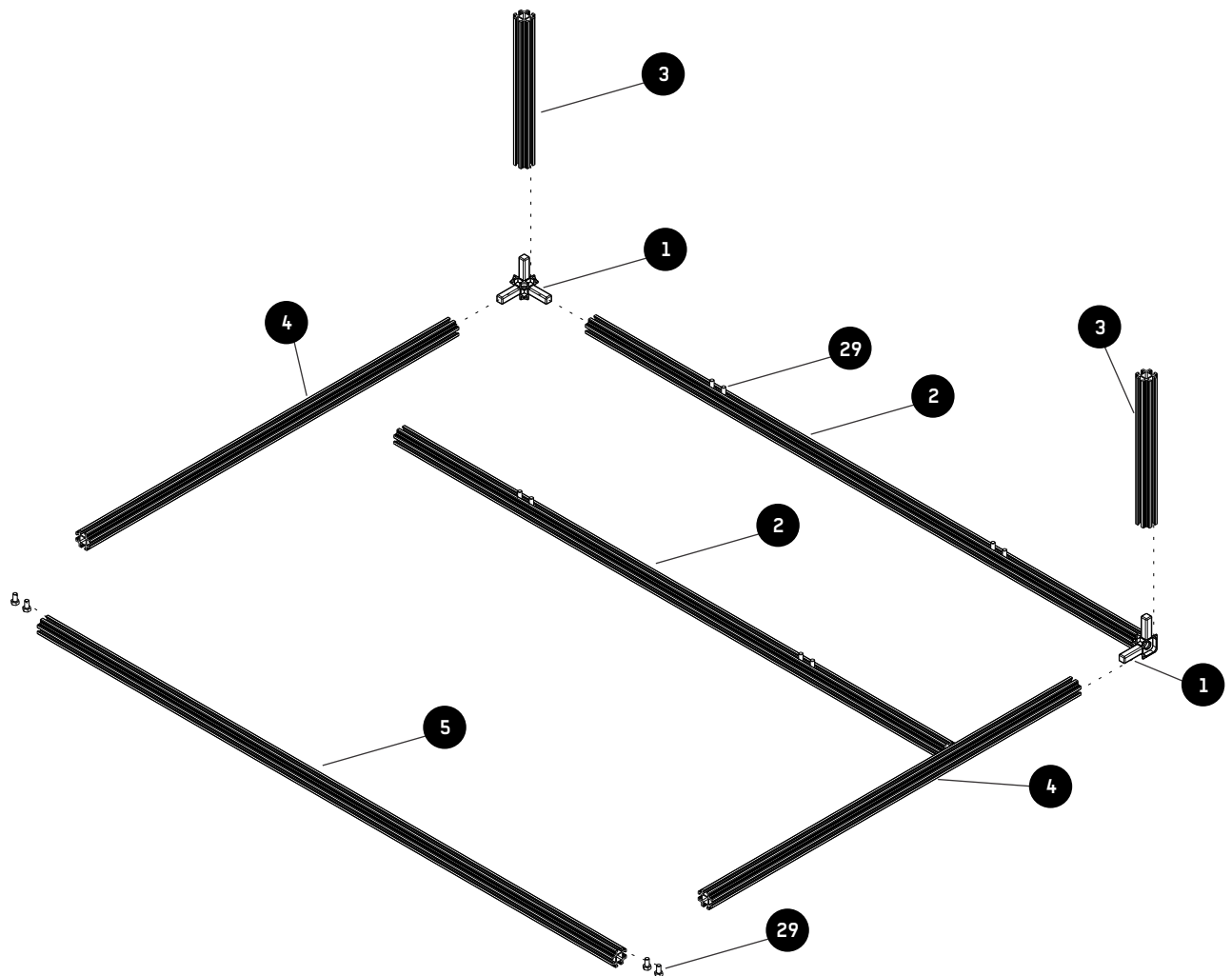

NOTE: Fasteners (Bolts and Nuts) only apply to the Top Frame Assembly.

2 SUB-ASSEMBLY 1

2.1

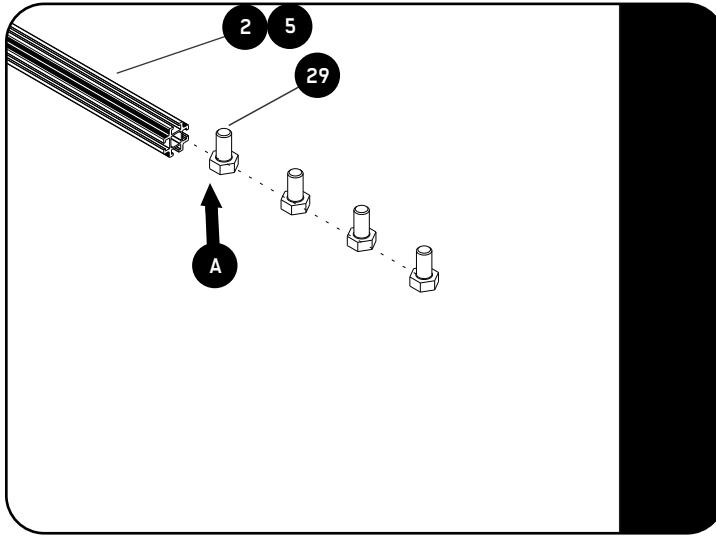

Load four M6 x 12 Hex Bolts (Item 29) into each of the the Front Extrusions (Item 2) and the Top Back Extrusion (Item 5), as shown in Fig. 2.1.

Place these on a flat, level surface, parallel to each other.

2.2

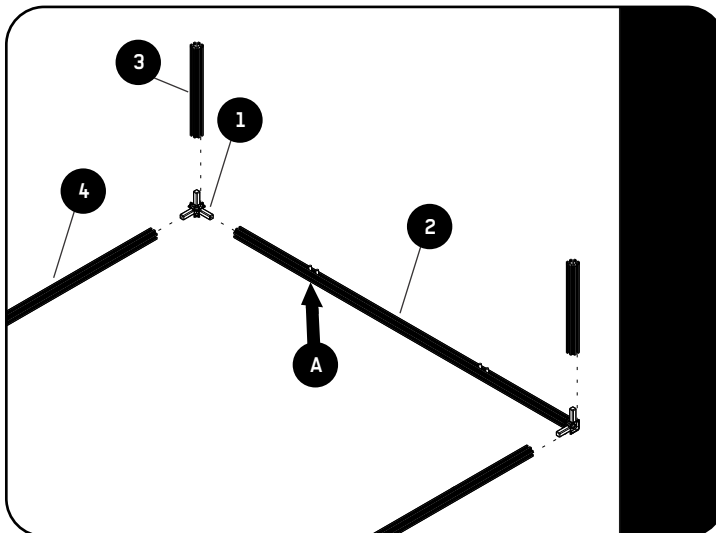

Loosely assemble one Front Extrusion (Item 2) and two Corners (Item 1).

Take Note of the Corner and Bolt orientations, as shown in Fig 2.1 and 2.2 (A). These should all be in the same T-slot in each extrusion, facing the same way.

Loosely assemble each Side Extrusion (Item 4) and each Front Leg Extrusion (Item 3) as shown in 2.2.



Take note of each Extrusion's length as shown on page 3. If the incorrect lengths are used, fitment in the vehicle will be incorrect.

2.3

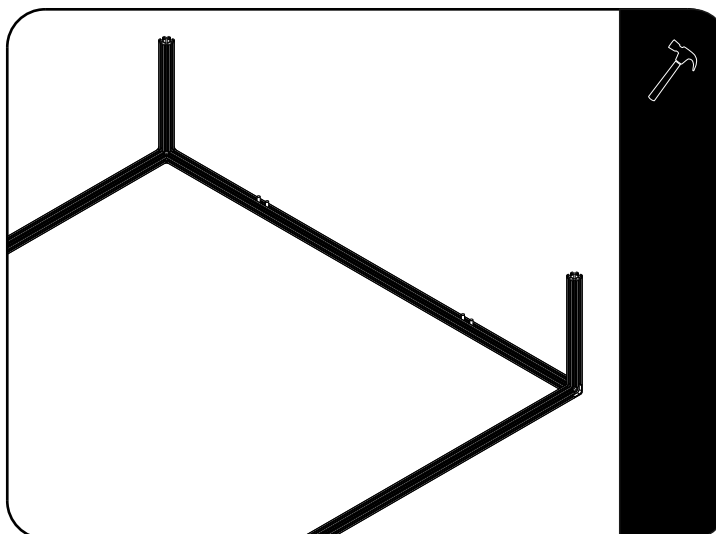

Use the Rubber Mallet to securely fit the corners so they are flush against each Extrusion. This will be the Top Front Frame.

The remaining Front Extrusion (Item 2) and Top Back Extrusion (Item 5) assembled with the Hex Bolts, in Step 2.1 should be kept aside for use in the next steps.

3

SUB-ASSEMBLY 2

IN THE BOX

1	1 X	Top Front Frame assembled in Step 2
2	1 X	Front Extrusion assembled in Step 2
15	6 X	M6 Thin Nut
16	6 X	M6 x 8 Button Head Bolt
27	2 X	Joiner Plate

TOOLS NEEDED



FIGURE 3.1

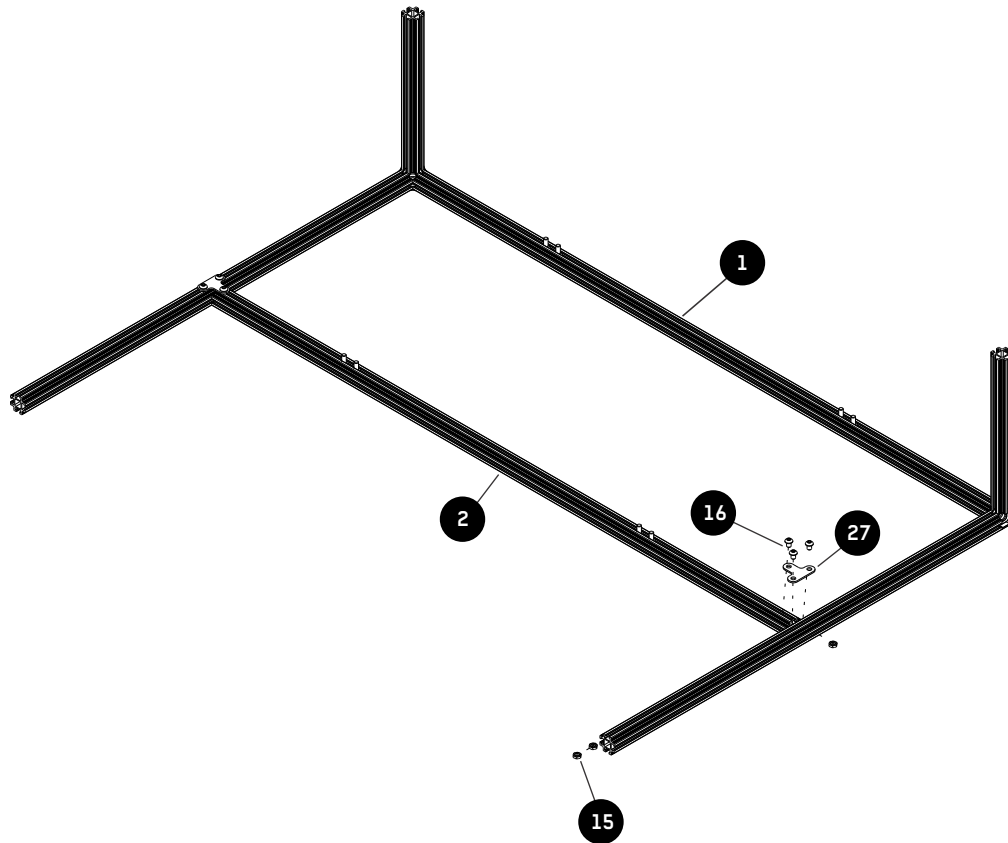

3

SUB-ASSEMBLY 2

3.1

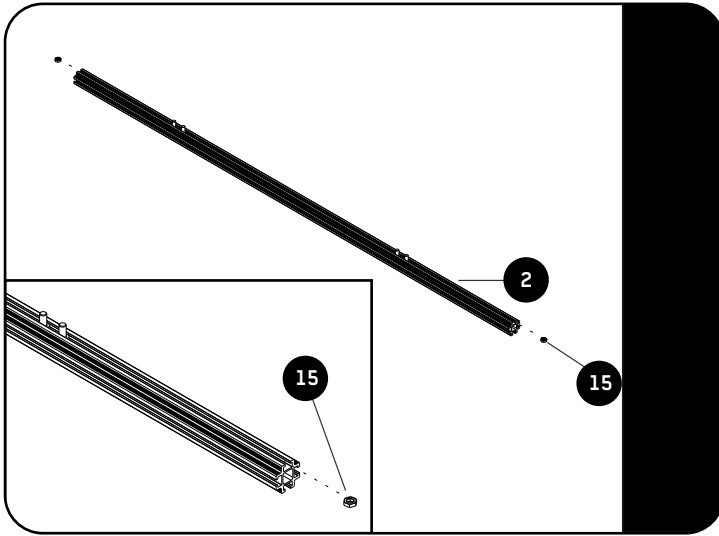

Starting with the remaining Front Extrusion (Item 2), as assembled in Step 2, load one M6 Thin Nut (Item 15) into each end, using the same T-slot (Top) as the Hex Bolts.

3.2

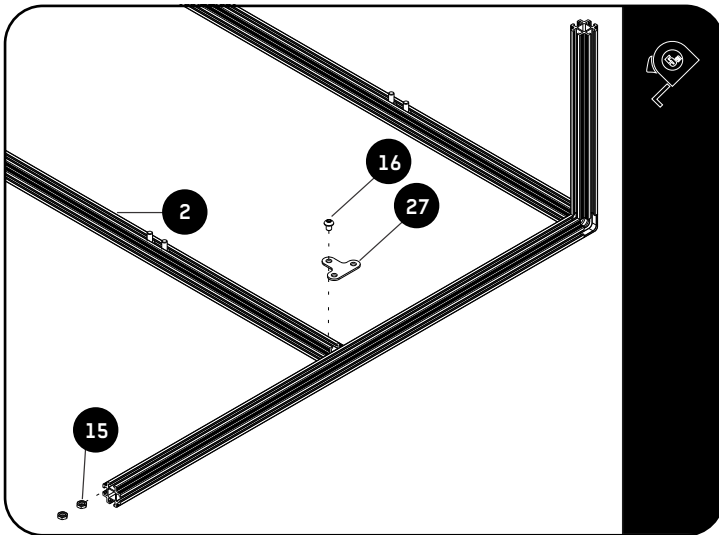

Load two M6 Thin Nuts (Item 15) into the Top T-Slot of the Side Extrusion on the each side of the Front Frame, as shown in step 3.1.

Loosely assemble the Joiner Plates (Item 27) on each end of the Extrusion (Item 2) using the M6 Thin Nuts (Item 15), loaded in Step 3.1 and M6 x 8 Button Head Bolts (Item 16).

3.3

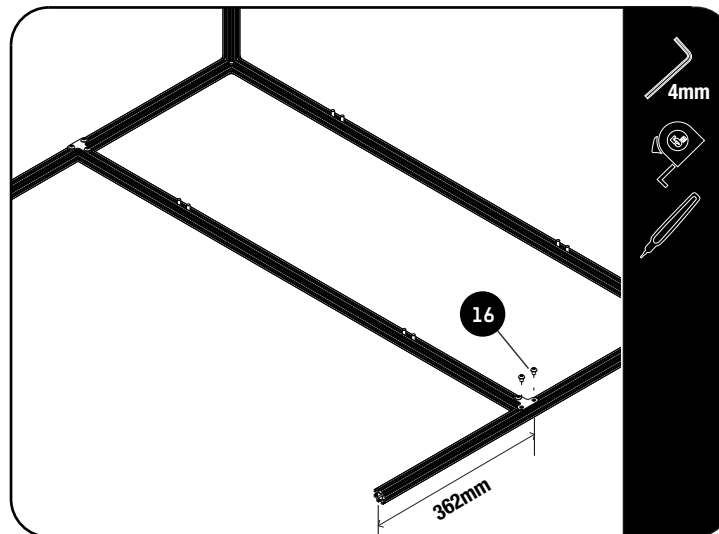

Align the two M6 Thin Nuts (Item 15) that were loaded in Step 3.2 with the holes in each Joiner Plate (Item 27). Do this for both sides.

Loosely assemble using two M6 x 8 Button Head Bolts (Item 16). Do this for both sides.

Measure 362mm from the ends of both Side Extrusions and make a mark with a marking pen.

Align the centre of the Extrusion with the mark made, but do not tighten fasteners yet.

4

SUB-ASSEMBLY 3

IN THE BOX

1	1 X	Top Front Frame assembled in Step 3
5	1 X	Top Back Extrusion assembled in Step 2
15	10 X	M6 Thin Nut
16	10 X	M6 x 8 Button Head Bolt
22	2 X	Back Completion Deck Support (1 LH & 1 RH)

TOOLS NEEDED



FIGURE 4.1

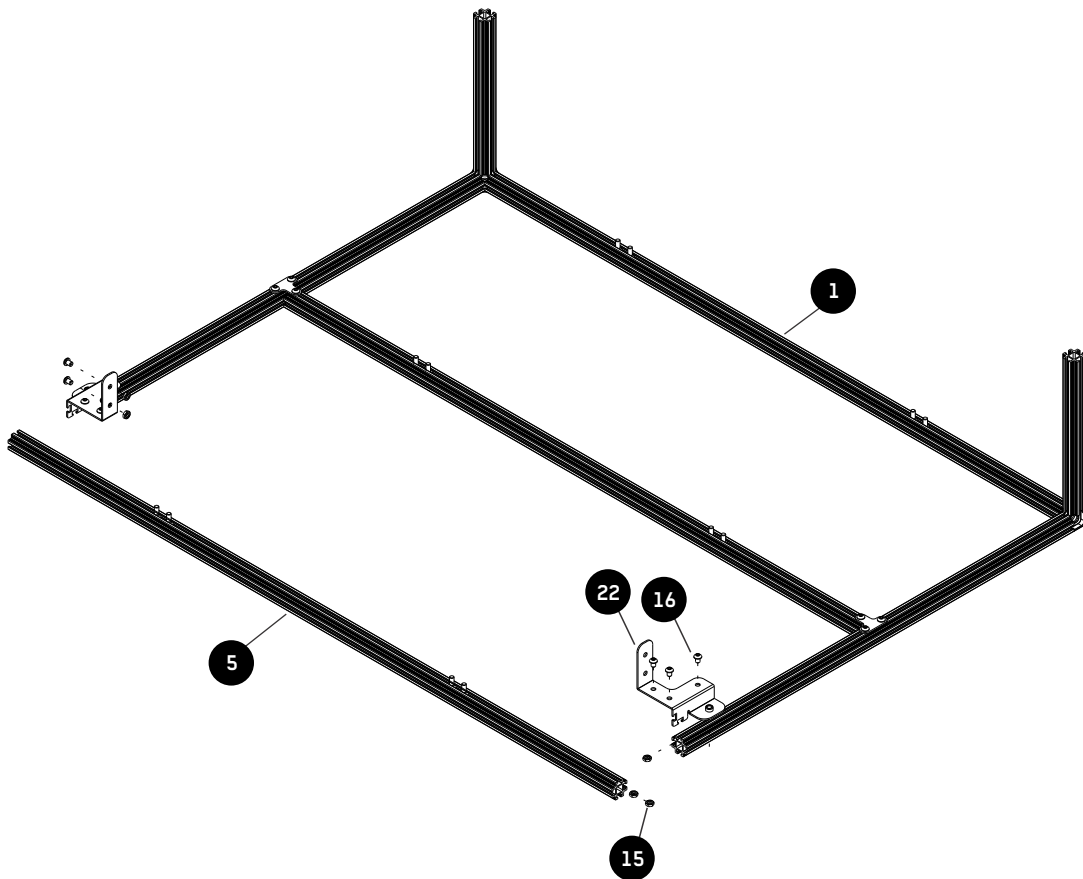

4.1

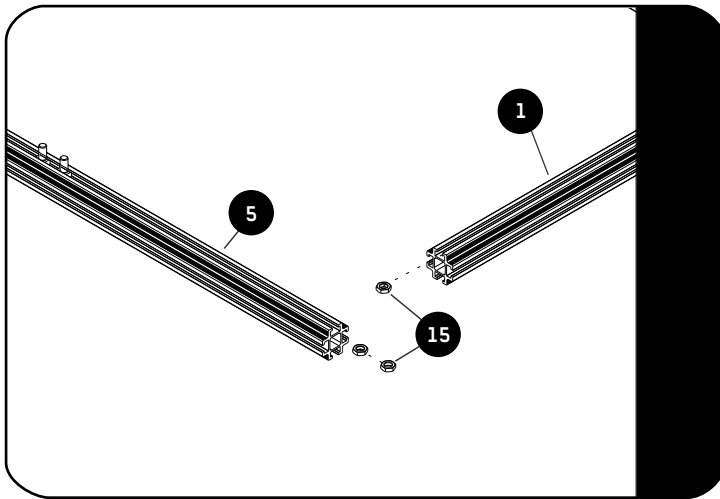

Starting on the Top Front Frame (Item 1) assembled in Step 3, load one M6 Thin Nut (Item 15) in the Top T-Slot of the Side Extrusion, as shown in Fig 4.1.

Load two M6 Thin Nuts (Item 15) into each end of the Top T-Slot of the Top Back Extrusion (Item 5) as assembled in Step 2, as shown in Fig 4.1.

4.2

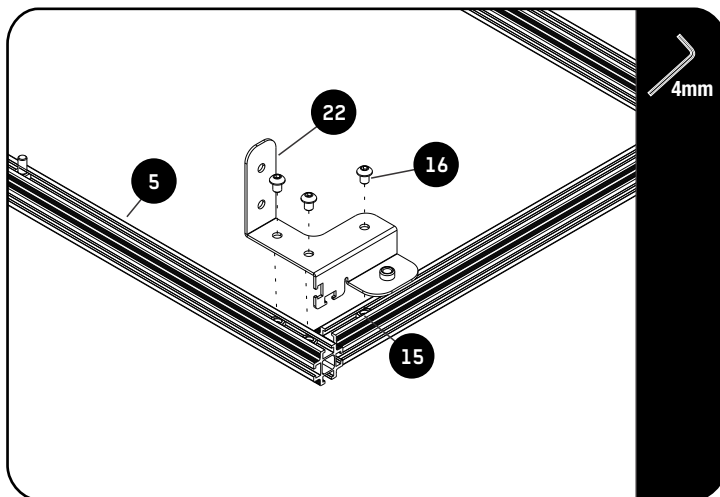

Loosely assemble the Back Completion Deck Support (Item 22) on each end of the Top Back Extrusion (Item 5) using the M6 Thin Nuts (Item 15), loaded in Step 4.1 and M6 x 8 Button Head Bolts (Item 16).



Take note of the Extrusion Positions and install the Support Bracket flush against the Top Back Extrusion.

Tighten these fasteners.



Tightening Torque:

M6 : 8-10Nm / 5.9 ft lb - 7.38 ft lb

4.3

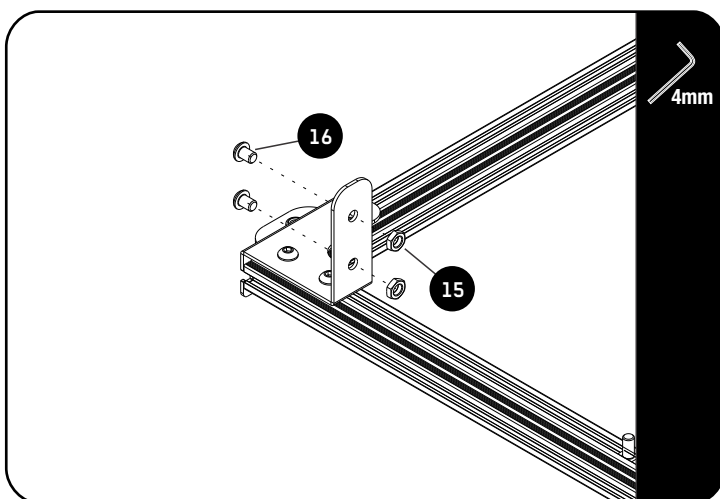

Loosely assemble two M6 x 8 Button Head Bolts (Item 16) and two M6 Thin Nuts (Item 15). Do this for both sides.



Do not turn the M6 Thin Nut more than once, as a loose assembly is required to slide in the Back Leg Extrusions in the next step.

5

SUB-ASSEMBLY 4

IN THE BOX

1	1 X	Top Front Frame assembled in Step 4
6	3 X	Back Leg Extrusion 224.6mm Long
7	1 X	Back Bottom Extrusion 999.6mm Long
15	6 X	M6 Thin Nut
16	6 X	M6 x 8 Button Head Bolt
27	2 X	Joiner Plate
29	8 X	M6 x 12 Hex Bolt (From Main Assembly pocket)

TOOLS NEEDED



FIGURE 5.1

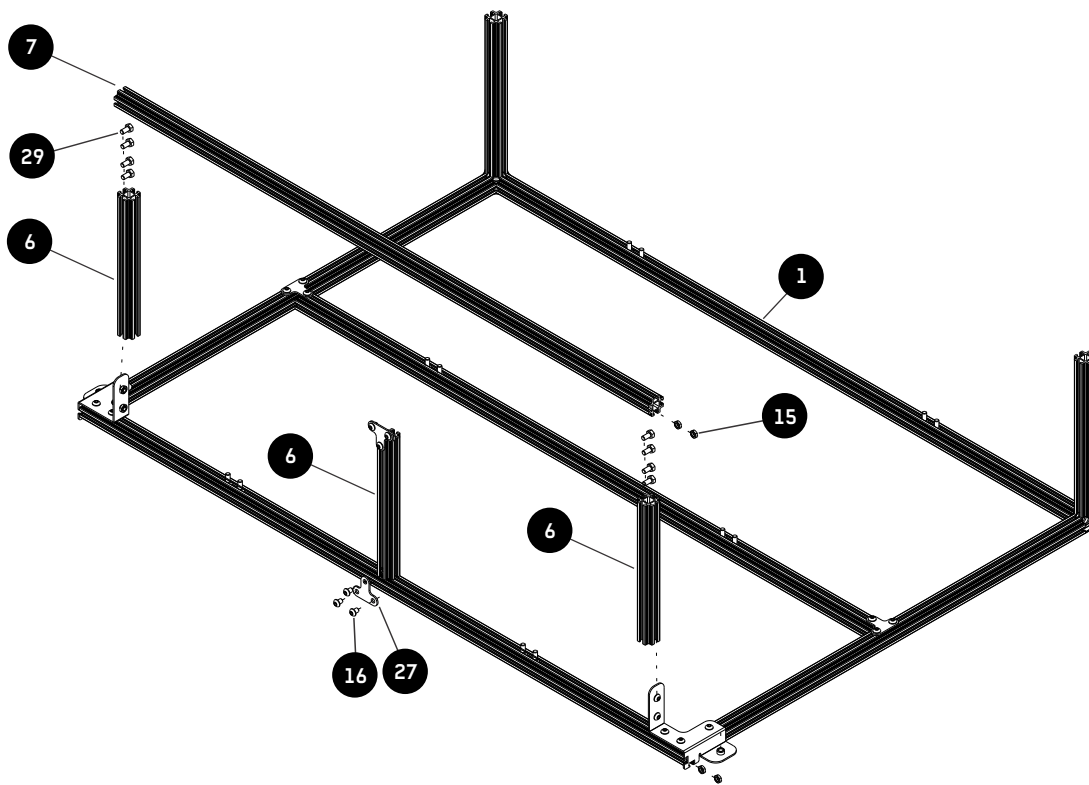

5.1

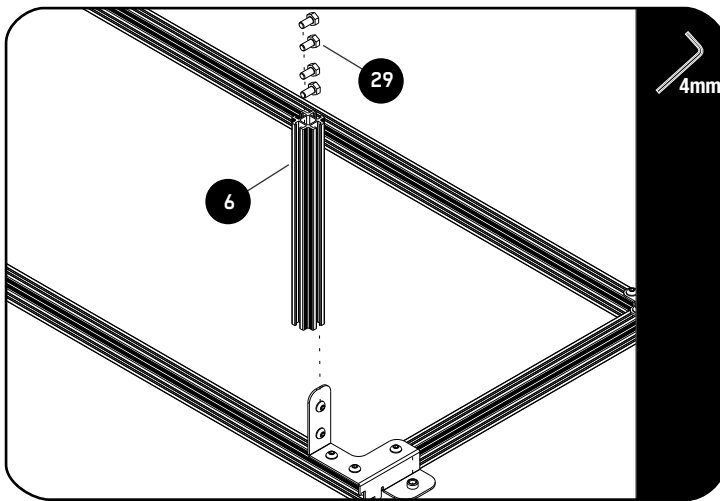

Starting with two of the Back Leg Extrusions (Item 6) assemble by sliding one of the T-Slots onto the Back Completion Deck Support using the fasteners assembled in Step 4.3.

Note the Back Leg Extrusion must rest on the Top Back Extrusion.

Tighten all the fasteners.



Tightening Torque:

M6 : 8-10Nm / 5.9 ft lb - 7.38 ft lb

Slide four M6 x 12 Hex Bolts (Item 29) into the Extrusions using the T-Slot facing the back.

5.2

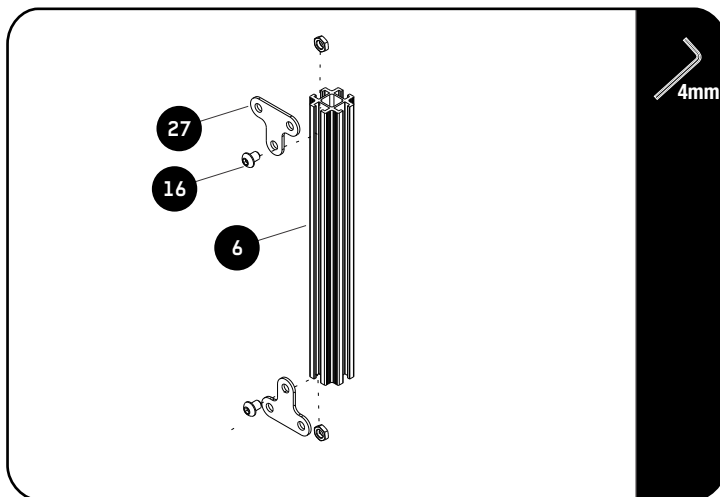

Load one M6 Thin Nut (Item 15) into the T-Slot of the remaining Back Leg Extrusion (Item 6), on each end.

Loosely assemble a Joiner Plate (Item 27) on each end using an M6 x 8 Button Head Bolt (Item 16).

5.3

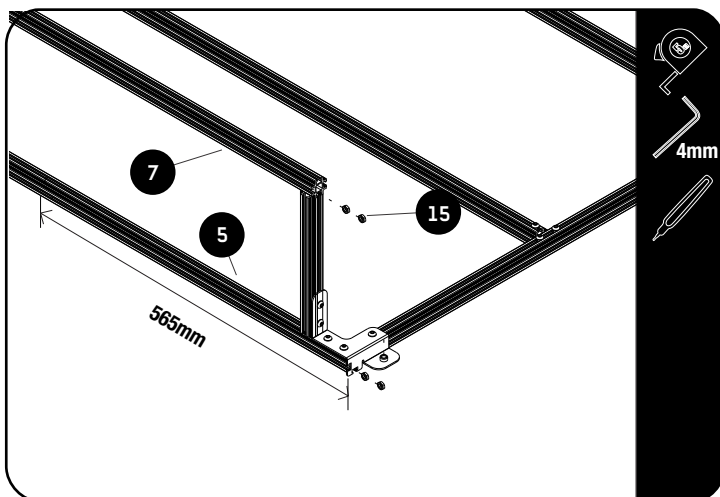

Measure 565mm from the end of the Top Back Extrusion and mark a mark with a marking pen.

Load two M6 Thin Nuts each (Item 15) into the Top Back Extrusion and the Bottom Back Extrusion (Items 5 & 7), as shown in Fig 5.3.



Note the orientation of the Thin Nuts in relation to the frame - placed in the outside T-Slot.

5

SUB-ASSEMBLY 4

5.4

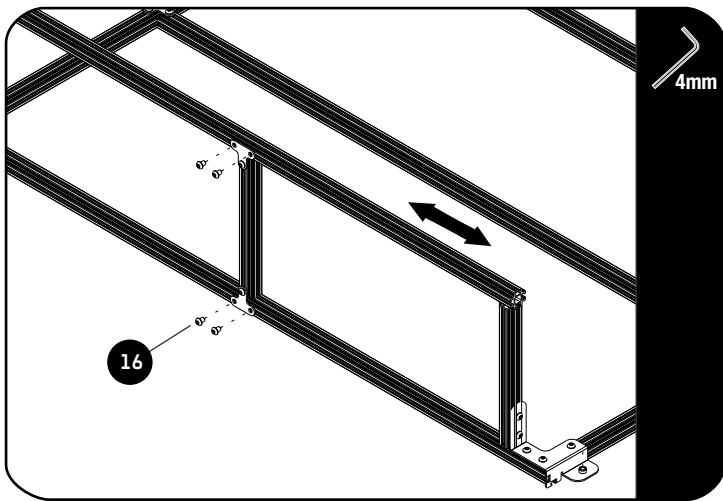

Align the center of the Back Leg Extrusion assembled in Step 5.2 with the mark made in Step 5.3.

Line up the two M6 Thin Nuts loaded in the Top - and Bottom Back Extrusions with the holes in the Joiner Plates and assemble using M6 x 8 Button Head Bolts (Item 16).

Tighten all fasteners on the Top Back Extrusion, but not on the Bottom Back Extrusion. The Bottom Back Extrusion should still slide freely on the Joiner Plate.



Tightening Torque:

M6 : 8-10Nm / 5.9 ft lb - 7.38 ft lb

6

SUB-ASSEMBLY 5

IN THE BOX

1	1 X	Frame assembled in Step 5
12	2 X	Front Mounting Bracket
13	2 X	Back Mounting Bracket
15	19 X	M6 Thin Nut
16	19 X	M6 x 8 Button Head Bolt
23	3 X	Mid Completion Deck Support
24	1 X	Front Completion Deck Support LH
25	1 X	Front Completion Deck Support RH

TOOLS NEEDED



FIGURE 6.1

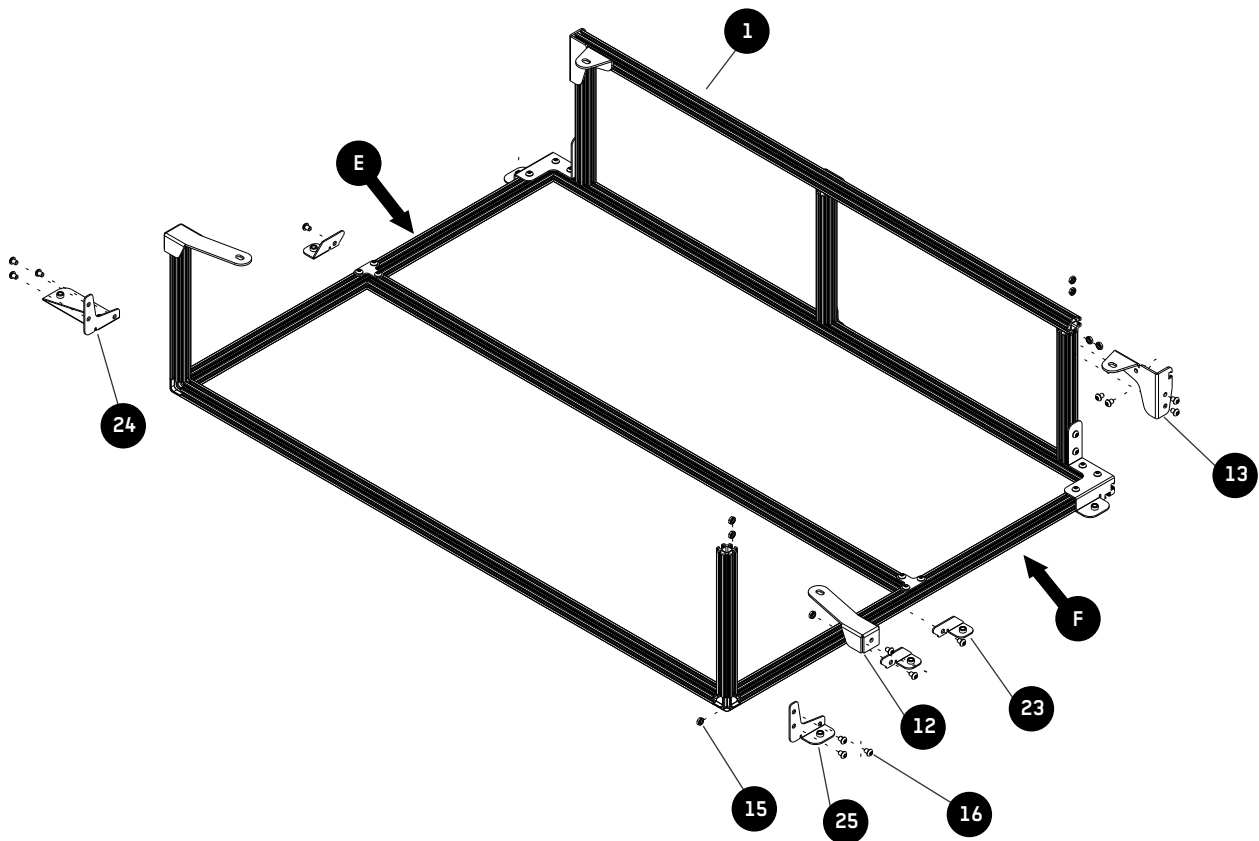

6.1

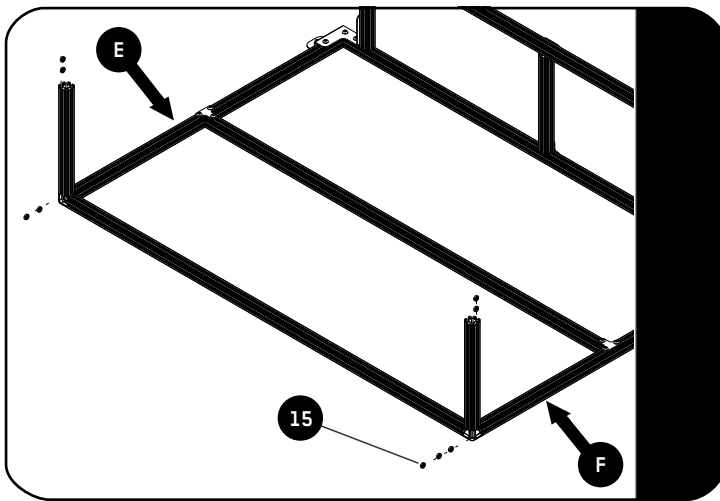

Load two M6 Thin Nuts (Item 15) into the Outer T-Slot of each Front Leg Extrusion on both sides.

Load two M6 Thin Nuts into the Left Side Extrusion (E) and three M6 Thin Nuts into the Right Side Extrusion (F), as shown in Fig 6.1. Use the Outer T-Slots of the Extrusions.

6.2

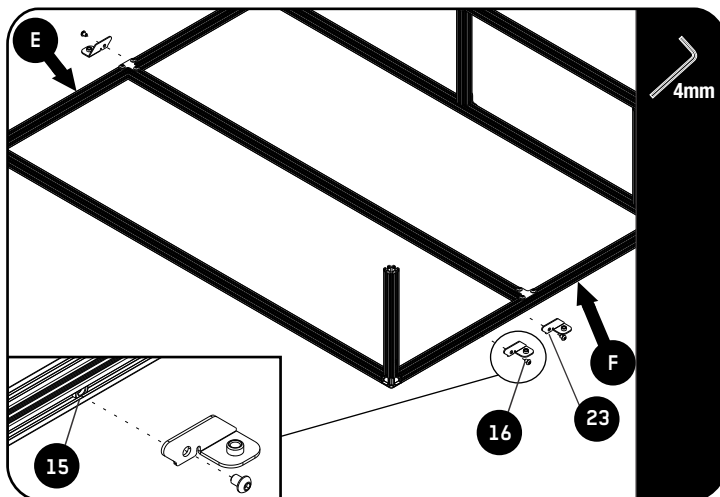

Loosely assemble one Mid Completion Deck Support Bracket (Item 23) on the Left side (E) using M6 x 8 Button Head Bolts (Item 16) and the Inner M6 Thin Nut (Item 15) as loaded in Step 6.1.

Loosely assemble two Mid Completion Deck Support Brackets (Item 23) on the Right side (F) using M6 x 8 Button Head Bolts (Item 16) and the Inner M6 Thin Nuts (Item 15) as loaded in Step 6.1.

These supports should be free to slide in the extrusion, and should not be tightened yet.



Take note of the orientation of the brackets in relation to the frame. If assembled incorrectly, all subsequent steps will be incorrect.

6.3

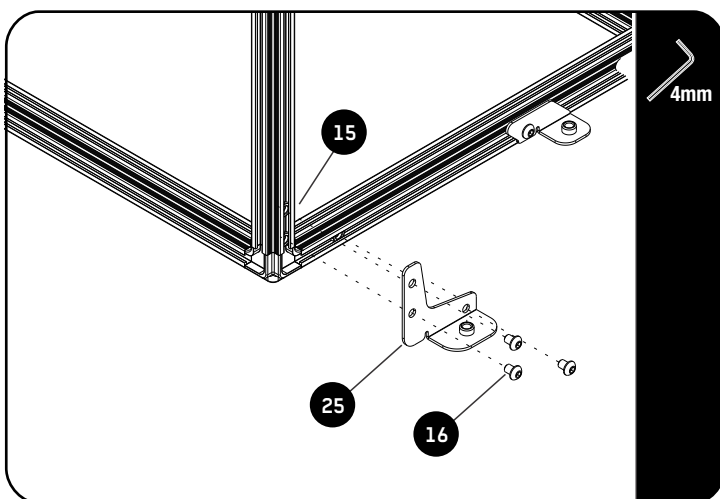

Loosely assemble the Front Completion Deck Support Bracket RH (Item 25) using M6 x 8 Button Head Bolts (Item 16) and the outer M6 Thin Nut in the Side Extrusion and the two M6 Thin Nuts in the Front Leg Extrusion (Item 15) as loaded in Step 6.1.

Repeat step above on the opposite side, using the Front Completion Deck Support Bracket LH (Item 24).



Tightening Torque:

M6 : 8-10Nm / 5.9 ft lb - 7.38 ft lb

6

SUB-ASSEMBLY 5

6.4

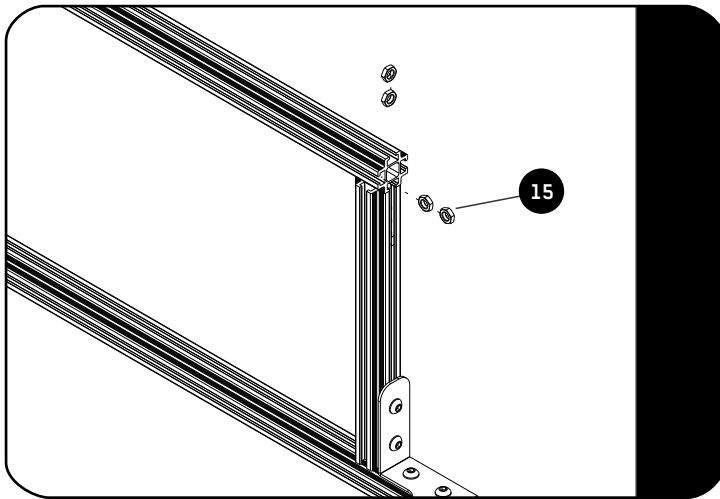

Load two M6 Thin Nuts (Item 15) into the Inner T-Slot of the Back Bottom Extrusion on both ends.

Load two M6 Thin Nuts (Item 15) into the Outer T-Slot of each Back Leg Extrusion on both sides.

Centralize the Bottom Back Extrusion and tighten the Joiner Plate Fasteners as mentioned in Step 5.4. The ends should be parallel to the outer T-Slot on each Back Leg Extrusion.



Tightening Torque:

M6 : 8-10Nm / 5.9 ft lb - 7.38 ft lb

6.5

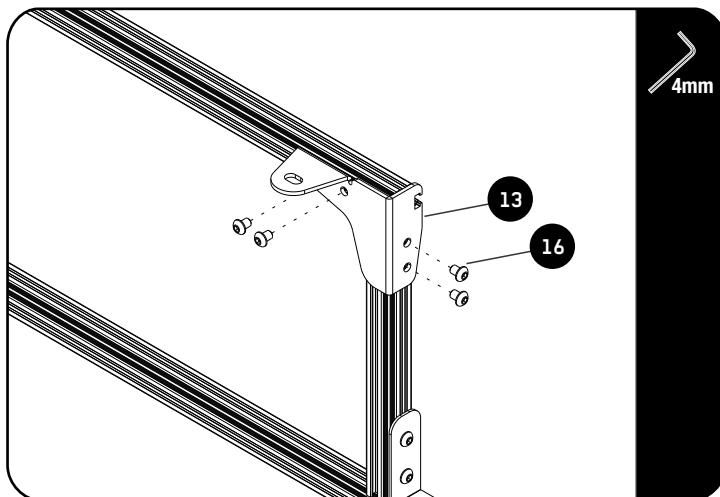

Loosely assemble one Back Mounting Bracket (Item 13) on each side using M6 x 8 Button Head Bolts (Item 16) and the M6 Thin Nuts (Item 15) as loaded in Step 6.4.

Make sure that the Bottom Back Extrusion is flush with the bracket and tighten all fasteners.



Tightening Torque:

M6 : 8-10Nm / 5.9 ft lb - 7.38 ft lb

6.6

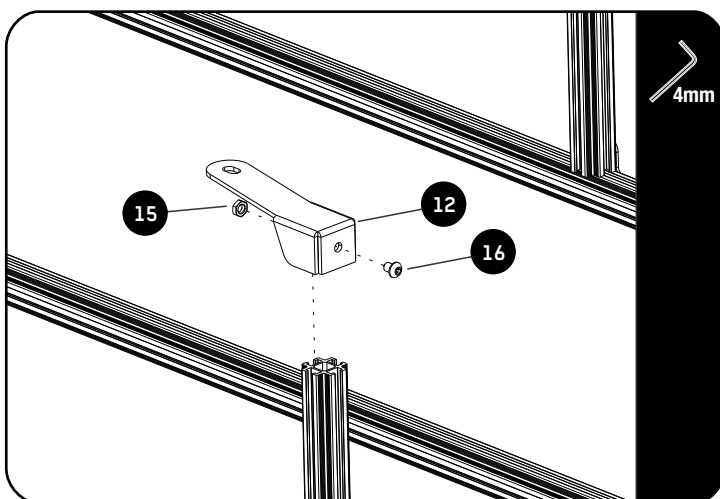

Loosely assemble the Front Mounting Bracket (Item 12) using one M6 Thin Nut and a M6 x 8 Button Head Bolt (Items 15 & 16). Turn the M6 Thin Nut only once.

Slide the assembly into the Front Leg Extrusion using the Outer T-Slot, until it is flush with the Extrusion top.

Tighten all Fasteners.



Take note that the Front Mounting Bracket Left and Right are interchangeable to accommodate different Mounting Points of different Models.



Tightening Torque:

M6 : 8-10Nm / 5.9 ft lb - 7.38 ft lb

7

SUB-ASSEMBLY 6

IN THE BOX

1	1 X	Frame assembled in Step 6
28	8 X	Spring Assembly
30	12 X	M6 Nyloc Nut
31	12 X	M6 Nut Cap

TOOLS NEEDED

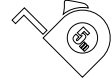
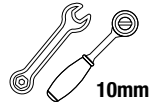

10mm

FIGURE 7.1

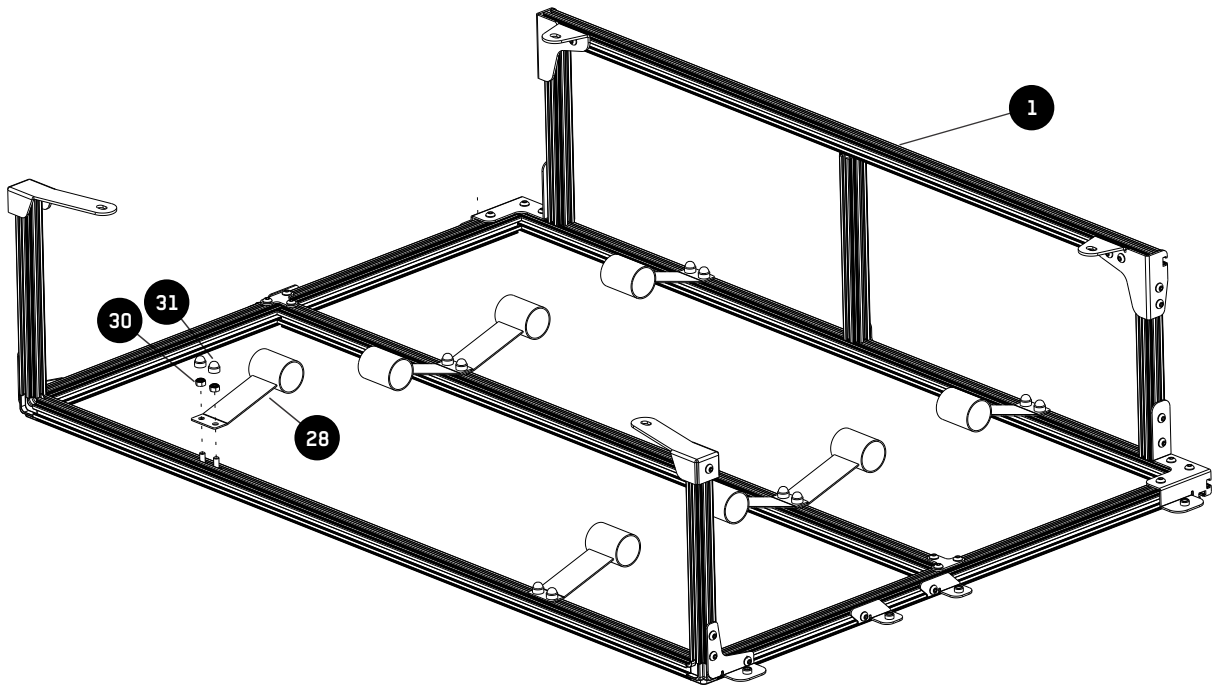

7

SUB-ASSEMBLY 6

7.1

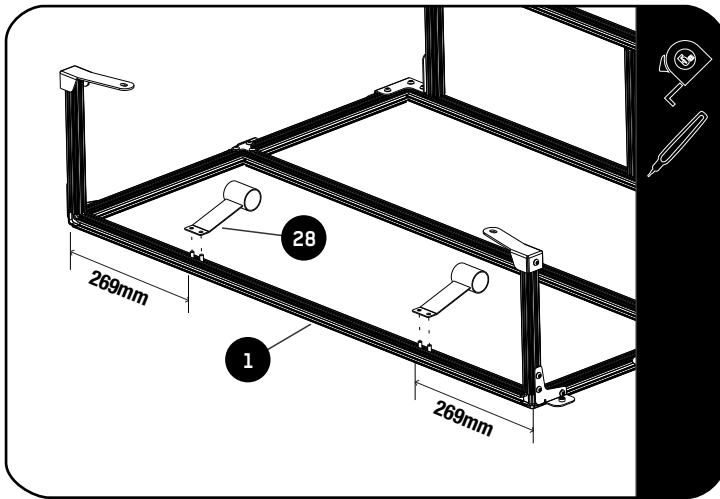

Using the Frame assembled in Step 6 (Item 1), measure 269mm from each end of the Front Extrusion, as shown and mark each Extrusion with a Marking Pen.

Using the Hex bolts loaded in 2.1 loosely assemble the Spring (Item 28) and align the center with the 269mm measurement.

Do this for the remaining springs.

7.2

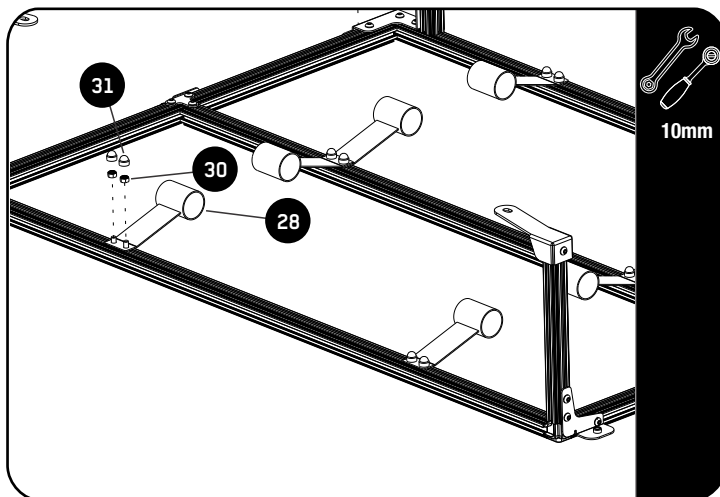

Assemble the Springs (Item 28) by placing them over the M6 x 12 Hex Bolts and using the M6 Nyloc Nuts (Item 30), as shown in Fig 7.1.

Two Springs will be fitted to the Middle Extrusion, pointing in opposite directions and using the same Hex Bolt set and the similar 269mm measurement.

Adjust Springs if necessary and tighten all fasteners.

Place M6 Nut Caps (Item 31) over each M6 Nyloc Nut.



Tightening Torque:

M6 : 8-10Nm / 5.9 ft lb - 7.38 ft lb

8

SUB-ASSEMBLY 7

IN THE BOX

1	1 X	Frame assembled in Step 7
8	2 X	Deck
9	8 X	Corner Brackets
10	8 X	Middle Brackets
11	16 X	M6 x 25 Countersunk Bolts
19	1 X	Completion Deck 01
20	1 X	Completion Deck 02
21	1 X	Completion Deck 03
26	8 X	M6 x 20 Countersunk Bolts

TOOLS NEEDED



FIGURE 8.1

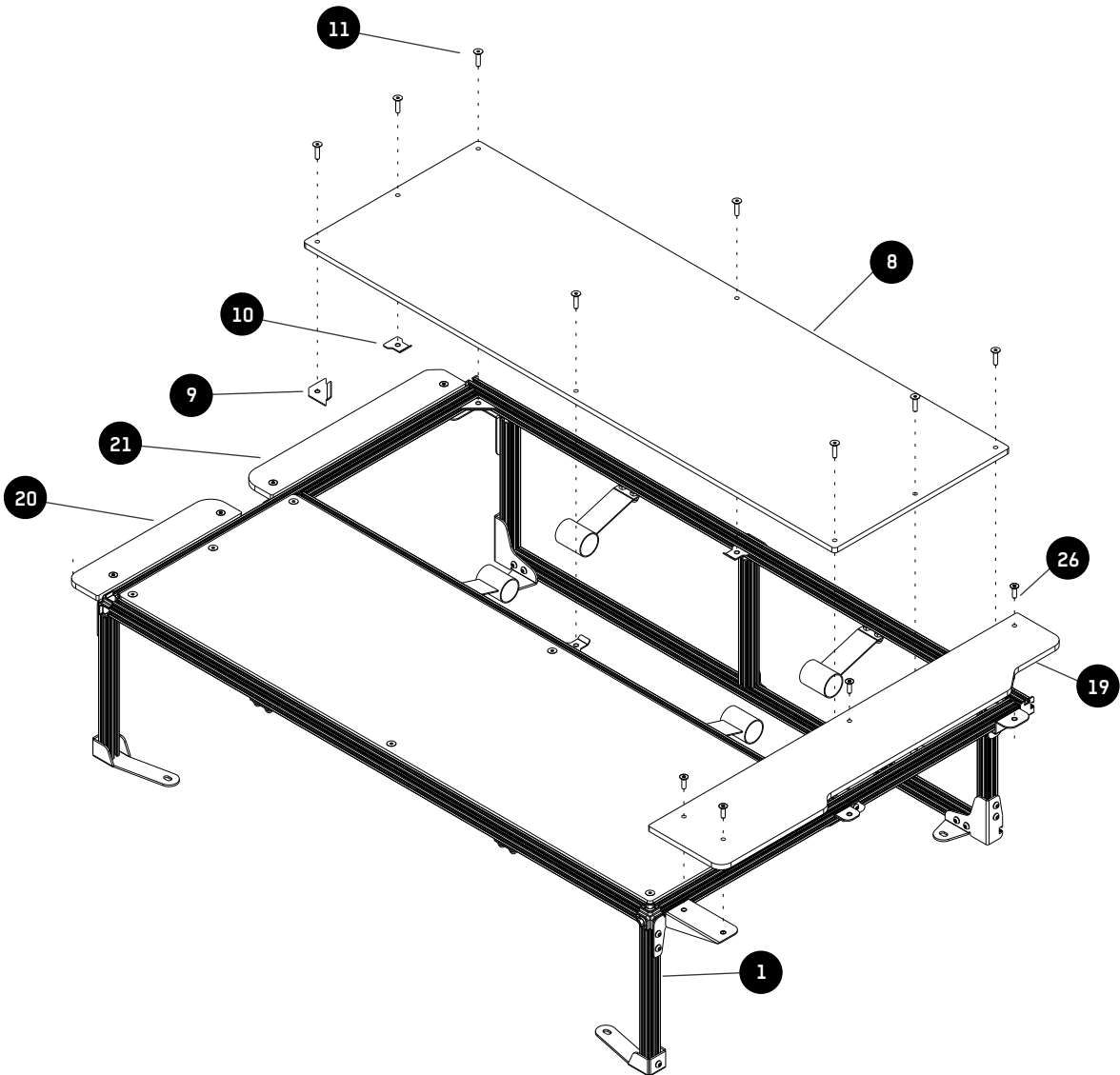

8.1

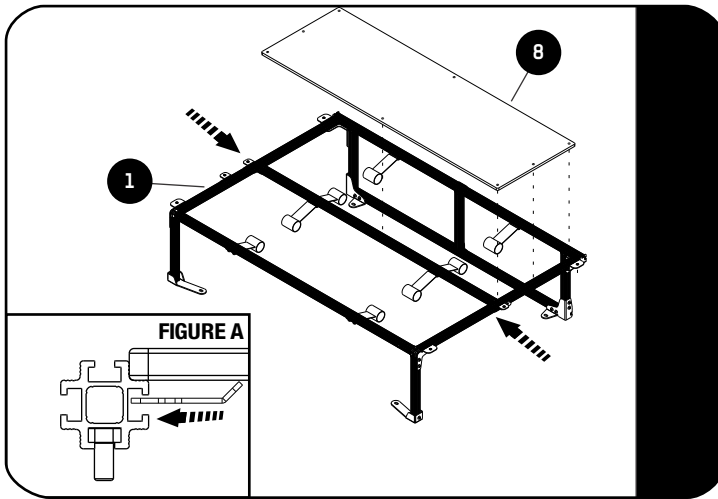

Place the Frame assembled in Step 7 (Item 1) on a flat surface with the Mounting Brackets facing down.

Place one Deck (Item 8) on the Frame, with the carpeted side facing up. The Deck should be flush against all the Extrusions, as shown in Fig. A.

Move the middle Front Extrusion with Joiner Plates (indicated by the arrows in Fig 8.1) flush against this Deck and tighten all fasteners on the Joiner Plates, as assembled in Step 3.3.



Tightening Torque:

M6 : 8-10Nm / 5.9 ft lb - 7.38 ft lb

8.2

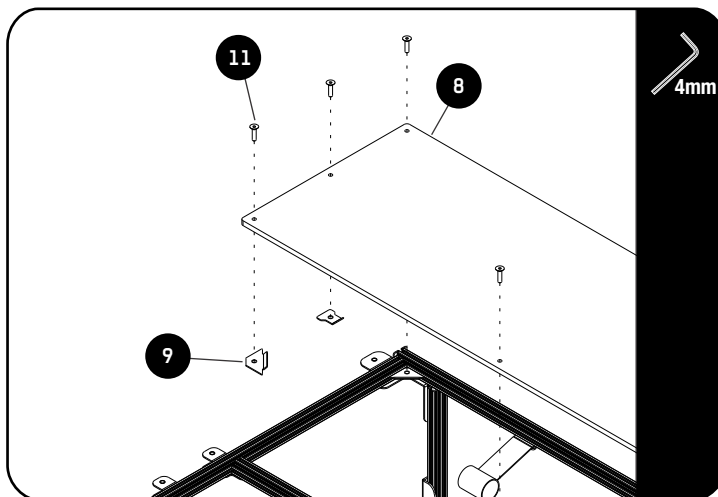

Place one Corner Bracket (Item 9) in a corner by slotting it into the inner slot of the Extrusion, as indicated by the arrow in Fig A, and align the hole with the hole on the Deck.

Assemble using one M6 x 25 Countersunk Bolt (Item 11).

Repeat for all Corners of the Deck.



NOTE: Do not over tighten - tighten until snug.



Tightening Torque:

M6 : 8-10Nm / 5.9 ft lb - 7.38 ft lb

8.3

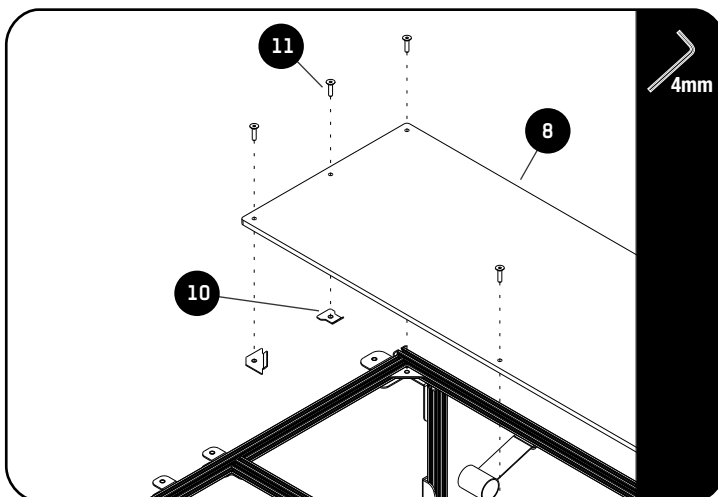

Place one Middle Bracket (Item 10) in the middle of the Deck by slotting it into the inner slot of the Extrusion and align the hole with the hole on the Deck.

Assemble using one M6 x 25 Countersunk Bolt (Item 11).

Repeat for all Middle points of the Deck.

Repeat Steps 8.1-8.3 to secure the remaining Deck to the frame.



Tightening Torque:

M6 : 8-10Nm / 5.9 ft lb - 7.38 ft lb

8.4

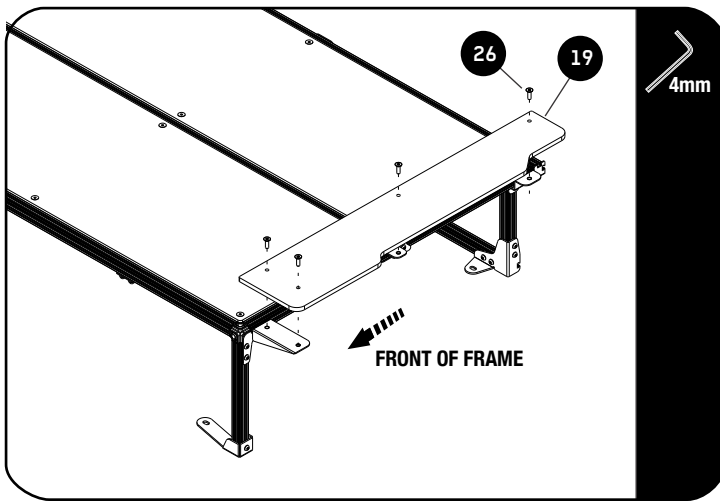

Loosely assemble Completion Deck 01 (Item 19) using four M6 x 20 Countersunk Bolts (Item 26) and the Front -, Mid - and Back Deck Support Brackets.

Tighten all Fasteners, including the Mid Deck Support Bracket as assembled in Step 6.2.



Take Note of the orientation of the Completion Deck in relation to the Frame.



Tightening Torque:

M6 : 8-10Nm / 5.9 ft lb - 7.38 ft lb

8.5

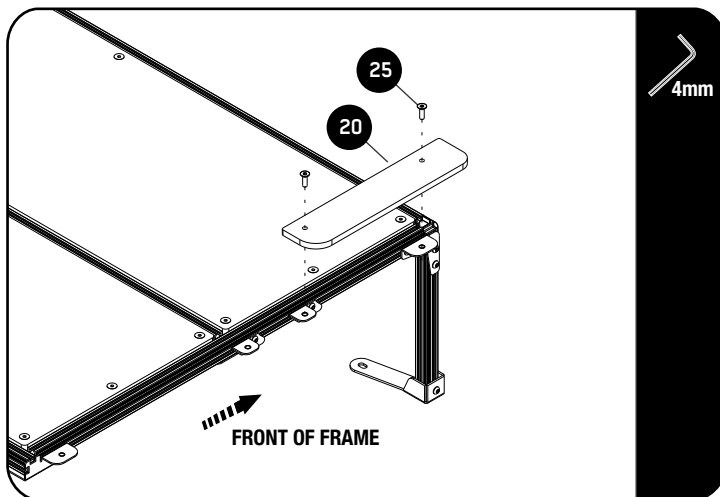

Loosely assemble Completion Deck 02 (Item 20) using two M6 x 20 Countersunk Bolts (Item 25) and the Front - and Mid Deck Support Brackets.

Tighten all Fasteners, including the Mid Deck Support Bracket as assembled in Step 6.2.



Take Note of the orientation of the Completion Deck in relation to the Frame.



Tightening Torque:

M6 : 8-10Nm / 5.9 ft lb - 7.38 ft lb

8.6

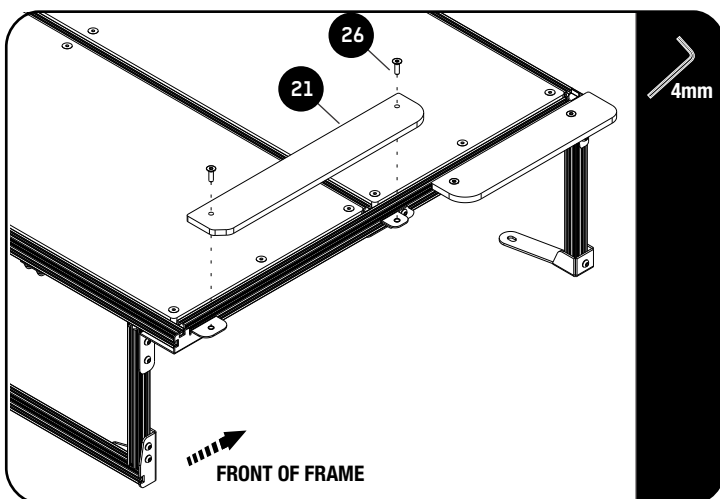

Loosely assemble Completion Deck 03 (Item 21) using two M6 x 20 Countersunk Bolts (Item 26) and the Mid - and Back Deck Support Brackets.

Tighten all Fasteners, including the Mid Deck Support Bracket as assembled in Step 6.2.



Take Note of the orientation of the Completion Deck in relation to the Frame.



Tightening Torque:

M6 : 8-10Nm / 5.9 ft lb - 7.38 ft lb

9

MAIN ASSEMBLY

IN THE BOX

1	1 X	Frame assembled in Step 8
14	4 X	Spacer 19 x 22
15	4 X	M6 Thin Nut
16	4 X	M6 x 8 Button Head Bolt
17	4 X	M8 x 16 x1.6 Flat Washer
18	4 X	M8 x 45 Button Head Bolt
29	12 X	M6 x 12 Hex Bolt
30	20 X	M6 Nyloc Nut
31	20 X	M6 Nut Cap
32	6 X	Corner Gusset

TOOLS NEEDED

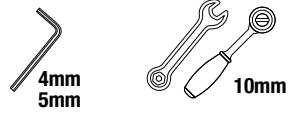
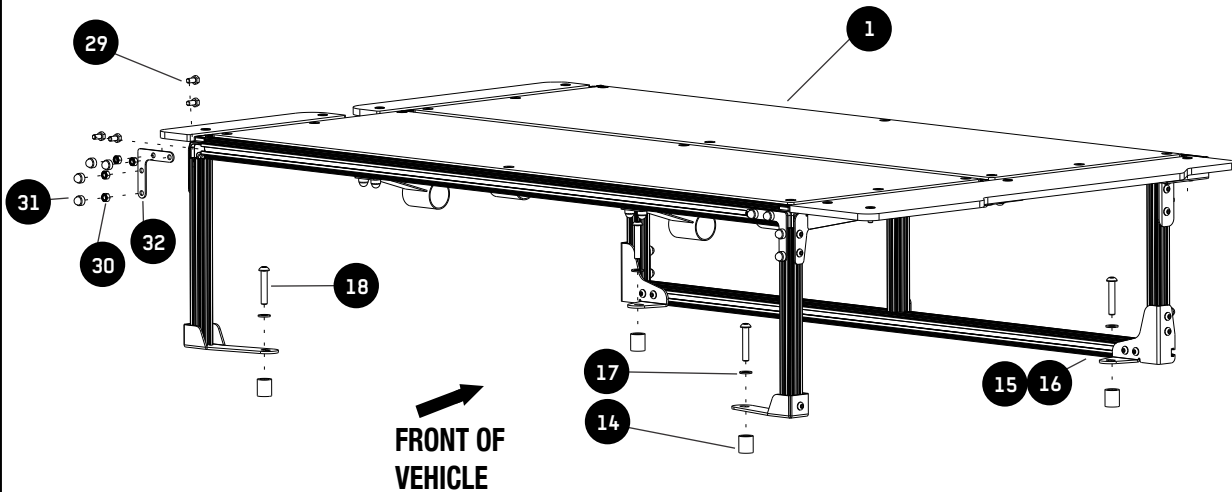
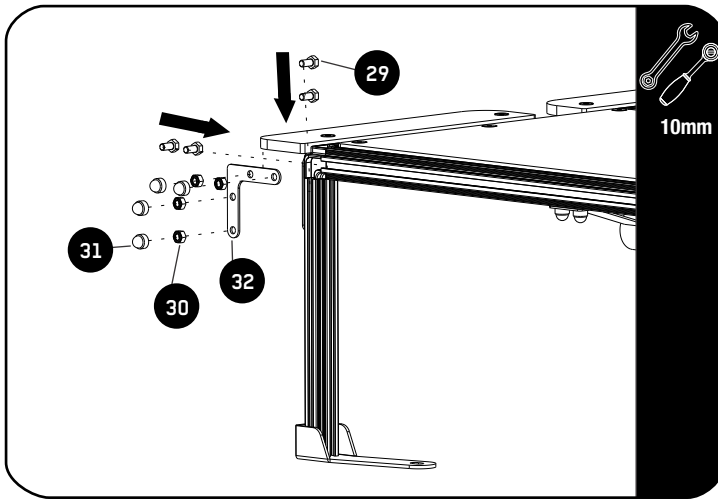

FIGURE 9.1



MAIN ASSEMBLY

9.1



With the front of the frame assembled in the previous step, facing you, load four M6 x 12 Hex Bolts (Item 29) into the front facing T-slots, as shown.

Secure the Corner Gussets (Item 32) to the top corners, using M6 Nyloc Nuts (Item 30).

Tighten all fasteners and place M6 Nut Caps (Item 31) on all Nyloc Nuts.

Do this on both top corners.



Tightening Torque:

M6 : 8-10Nm / 5.9 ft lb - 7.38 ft lb

9.2

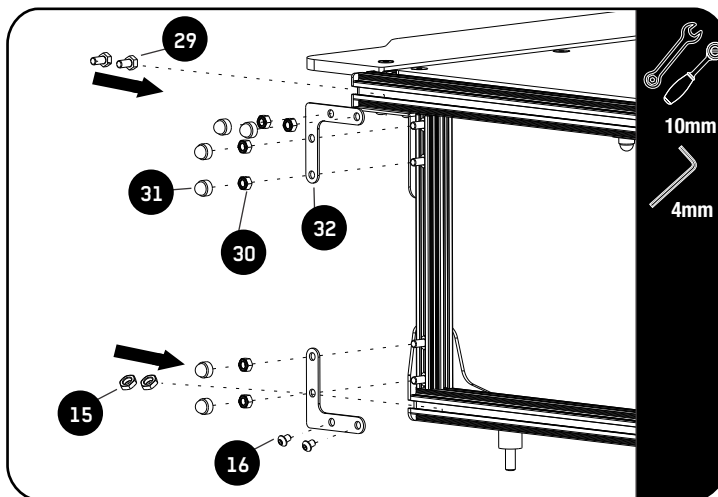

Turn the frame 180 degrees, with the back facing you. Load two M6 x 12 Hex Bolts (Item 29) into the back facing horizontal T-slot on the Top Extrusion, as shown. Load two M6 Thin Nuts (Item 15) into the back facing horizontal T-slot on the Bottom Extrusion, as shown. The M6 x 12 Hex Bolts loaded in Step 5.1 will be used, two for the bottom gusset and two for the top.

Secure the Corner Gussets (Item 32) to the top and bottom corners, using M6 Nyloc Nuts (Item 30). Where the M6 Thin Nuts are placed, use M6 x 8 Button Head Bolts (Item 16).

Tighten all fasteners and place M6 Nut Caps (Item 31) on all Nyloc Nuts.

Do this on both sides.



Tightening Torque:

M6 : 8-10Nm / 5.9 ft lb - 7.38 ft lb

9.3



If your vehicle is fitted with rails in the loading bay remove the caps, as shown to reveal the OEM Mounting Points. Remove any other accessories fitted to these OEM Mounting Points and remove the OEM Bolts.

Place the four Spacers (Item 14) over the four OEM Mounting Points in the vehicle.

9.4

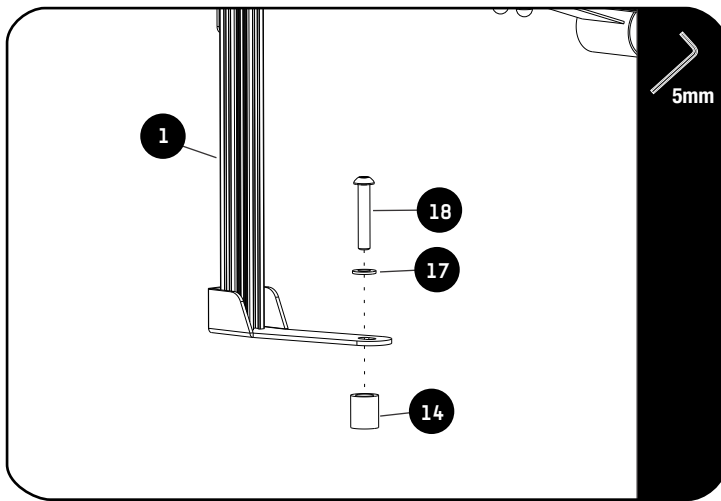

Place the Frame built in Step 8 (Item 1) in the vehicle so the spacers and OEM Mounting Points line up with the the corresponding holes on the feet of the frame.

Loosely assemble using a M8 x 16 x 1.6 Flat Washer (Item 17) and a M8 x 45 Button Head Bolt (Item 18) on each corner.

Tighten all fasteners to the vehicle.



Tightening Torque:

M8 : 15-20Nm / 11.06 ft lb - 14.75 ft lb

10

BOX PLACEMENT AND COMPLETION

10.1 Load your Modular Drawer system with four SBOX031 - noting the orientation.

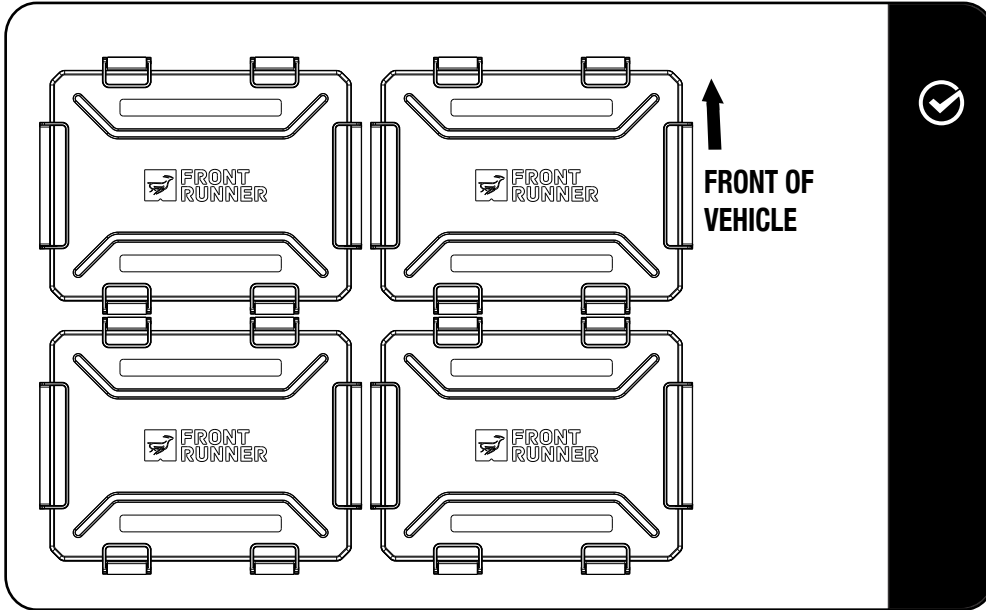

Congratulations! You did it. Take a step back and admire your work!

Front Runner will not be responsible for any damage caused by the failure to install the product according to these instructions. Please call us if you have any questions about the installation of this product.

INSTALL OTHER VEHICLE AND RACK ACCESSORIES

Now's the time to visit your favorite Front Runner Dealer in person or Online.

Be sure to tag us. We love to see our gear in action! #FrontRunnerOutfitters #BornToRoam

Share your adventures on: 