

START HERE!

READ ME FIRST

Don't be a hero and muscle through this installation without reading these fitting instructions first! Improper installation of this gear may void certain aspects of your warranty.

Before you begin, take a moment and open all your Front Runner Rack Kit boxes and gather the assembly instructions for the various components.

A complete kit will contain:

1. Front Runner Mounting System specific to your vehicle
2. Front Runner Rack Tray or Load Bar Slats

This document will guide you through the assembly of the Mounting System and assist you in fitting the Rack tray or Load Bars to your specific vehicle. Please refer to the next page for a list of all the components, quantities and tools required.

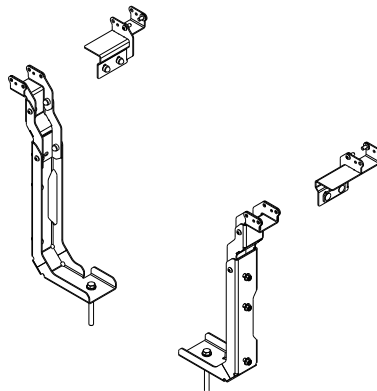

IMPORTANT WARNING!

IT IS CRITICAL THAT ALL FRONT RUNNER PRODUCTS BE PROPERLY AND SECURELY ASSEMBLED AND ATTACHED TO YOUR VEHICLE. IMPROPER ATTACHMENT COULD RESULT IN AN AUTOMOBILE ACCIDENT, AND COULD CAUSE SERIOUS BODILY INJURY OR DEATH. YOU ARE RESPONSIBLE FOR ASSEMBLING AND SECURING ALL FRONT RUNNER PRODUCTS TO YOUR VEHICLE, CHECKING THE ATTACHMENTS PRIOR TO USE, AND PERIODICALLY INSPECTING THE PRODUCTS FOR ADJUSTMENT, WEAR AND DAMAGE. THEREFORE, YOU MUST READ AND UNDERSTAND ALL OF THE INSTRUCTIONS AND PRECAUTIONS SUPPLIED WITH YOUR FRONT RUNNER PRODUCT PRIOR TO INSTALLATION OR USE. IF YOU DO NOT UNDERSTAND ALL OF THE INSTRUCTIONS AND CAUTIONS, OR IF YOU HAVE NO MECHANICAL EXPERIENCE AND ARE NOT THOROUGHLY FAMILIAR WITH THE INSTALLATION PROCEDURES, YOU SHOULD HAVE THE PRODUCT INSTALLED BY A PROFESSIONAL INSTALLER OR OTHER QUALIFIED PERSONNEL.

NOTE: Front Runner will not be responsible for any damage caused by the failure to install the product according to these instructions.

Please call us if you have any questions about the installation of this product.



1 GET ORGANIZED

IN THE BOX		PBTT002
1	1 X	LH BED STIFFENER
2	2 X	REAR TOP MAIN BRACKET
3	4 X	REAR BRACKET GUSSET
4	8 X	M8 X 16 BUTTON HEAD SCREW
5	18 X	M8 NYLOC NUT
6	12 X	M8 NUT CAP
7	1 X	RH BED STIFFENER
8	1 X	FRONT LH CHANNEL MOUNT
9	1 X	FRONT RH CHANNEL MOUNT
10	12 X	M8 X 19 X 2 FLAT WASHER
11	6 X	M8 X 25 HEX BOLT
12	4 X	M8 X 20 BUTTON HEAD SCREW
13	4 X	M8 X 19 X 3 FLAT WASHER

IN THE BOX		PBTT002
14	2 X	M8 CHANNEL PLATE
15	4 X	M8 X 25 CARRIAGE BOLT
16	4 X	M8 X 16 X 1.6 FLAT WASHER
17	2 X	10mm BED SPACER
18	2 X	6mm BED SPACER
19	2 X	M12 FLAT WASHER
20	2 X	M12 X 120 HEX BOLT
21	2 X	M12 NUT CAP
22	4 X	M8 X 25 BUTTON HEAD BOLT

TOOLS NEEDED

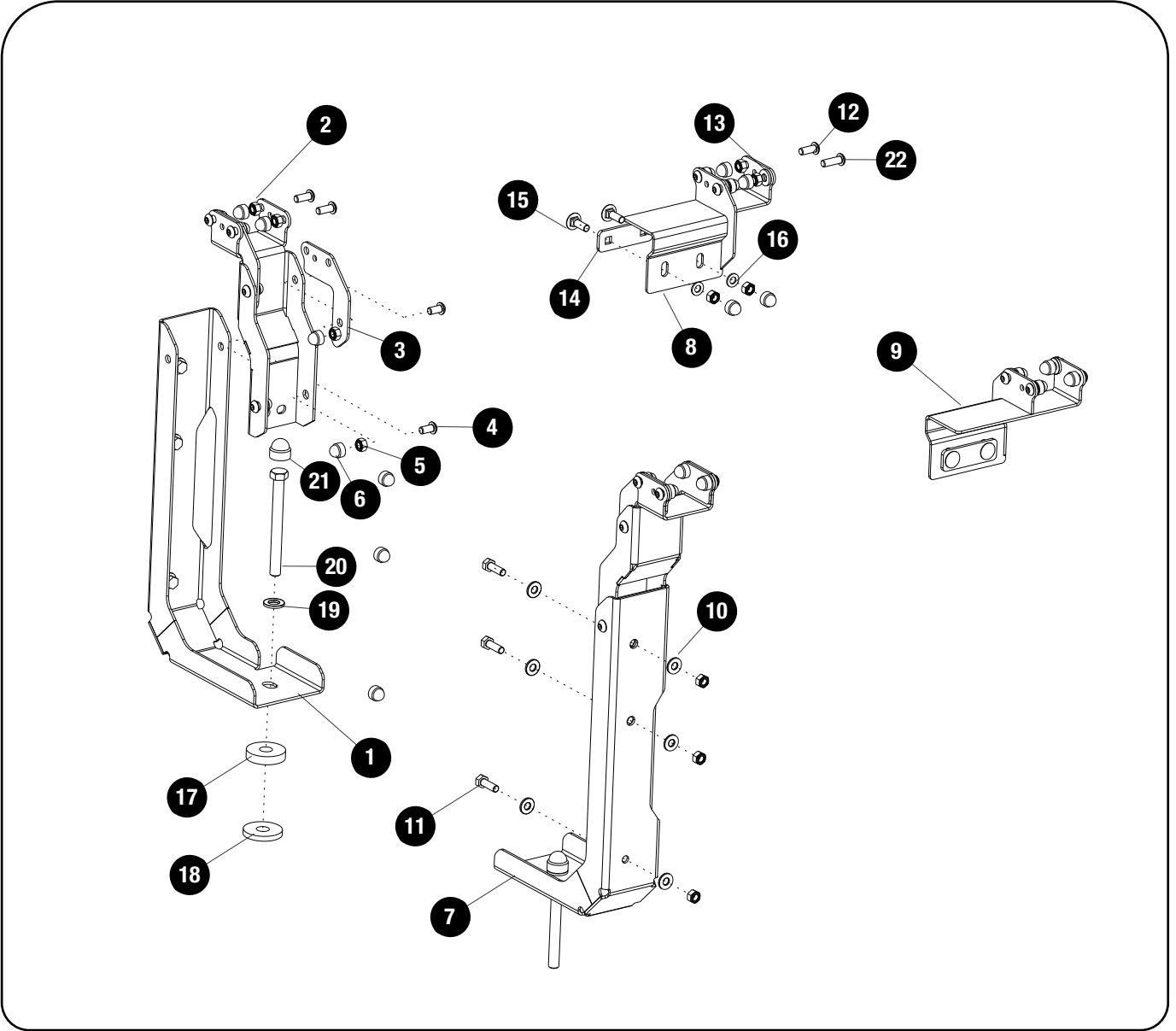



1 GET ORGANIZED

IN THE BOX		PBRA001
1	4 X	PRO BED RACK LEG
2	2 X	PRO BED RACK REAR BRACE
3	2 X	PRO BED RACK RH REAR WING BRACKET
4	2 X	PRO BED RACK TOP TRUSS
5	1 X	PRO BED RACK RH FRONT DIAGONAL BRACE
6	1 X	PRO BED RACK LH FRONT DIAGONAL BRACE
7	12 X	M6 x 16 BUTTON HEAD SCREW
8	22 X	M6 NYLOC NUT
9	22 X	M6 NUT CAP
10	16 X	M8 x 20 BUTTON HEAD SCREW
11	16 X	M8 x 19 x 2 FLAT WASHER
12	16 X	M8 NYLOC NUT
13	16 X	M8 NUT CAP

IN THE BOX		PBRA001
14	6 X	M6 x 12 BUTTON HEAD SCREW
15	2 X	FRONT HORIZONTAL BRACE
16	1 X	FRONT CENTER BRACE
17	4 X	M6 x 20 BUTTON HEAD SCREW
18	8 X	M6 x 12 x 1 FLAT WASHER
19	24 X	M6 x 25 THREAD FORMING SCREW
20	1 X	T30 6" TORX BIT

TOOLS NEEDED

13mm
10mm

5mm
4mm

Torx
T30/T55

Oil or
Anti Seize

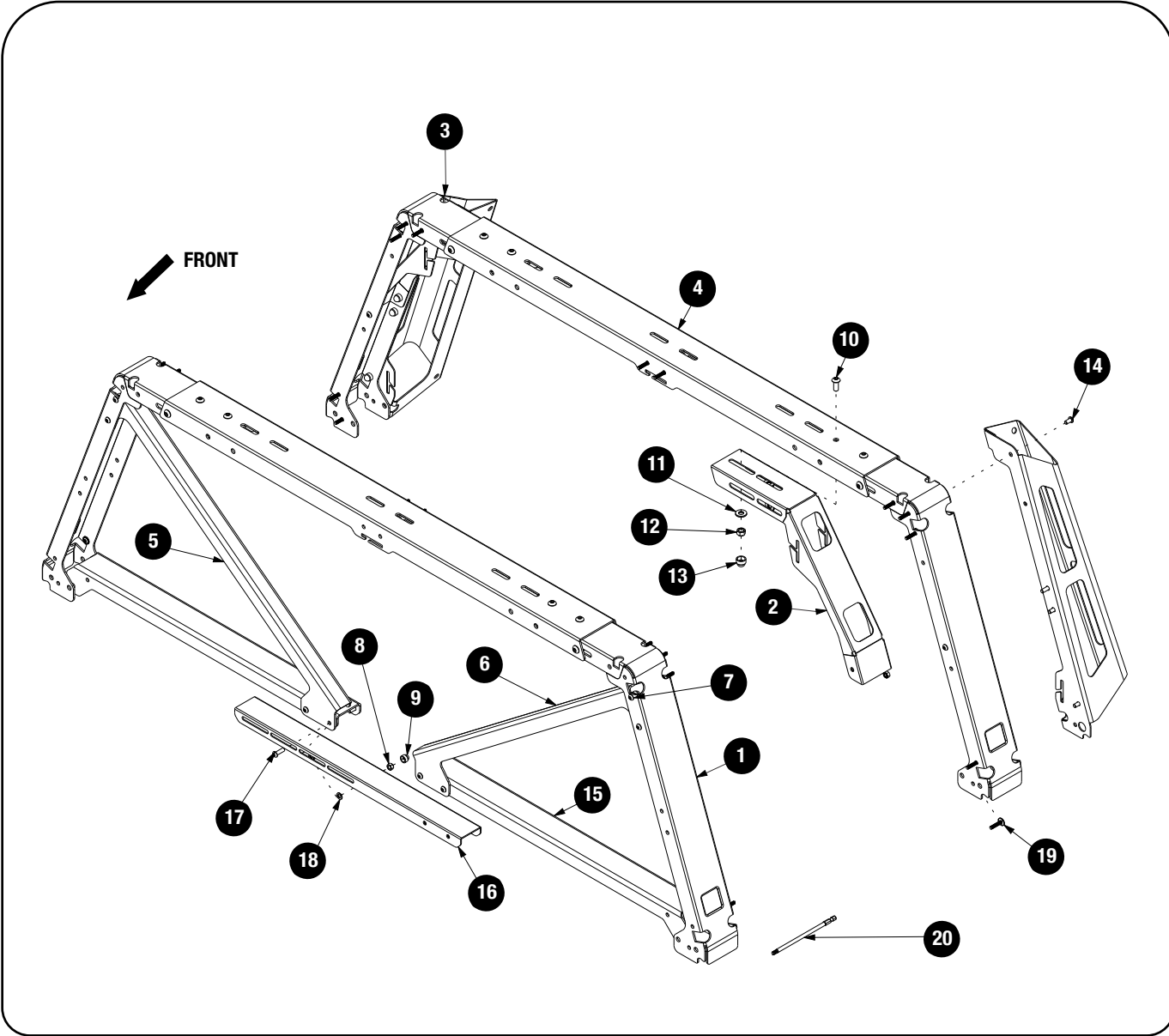



1

GET ORGANIZED

IN THE BOX

PBAL_1450

1	2 X	TOP EXTRUSION
2	1 X	TOP MIDDLE EXTRUSION
3	2 X	BOTTOM EXTRUSION
4	2 X	1450mm PSA STRIP PE60

TOOLS NEEDED



Friend

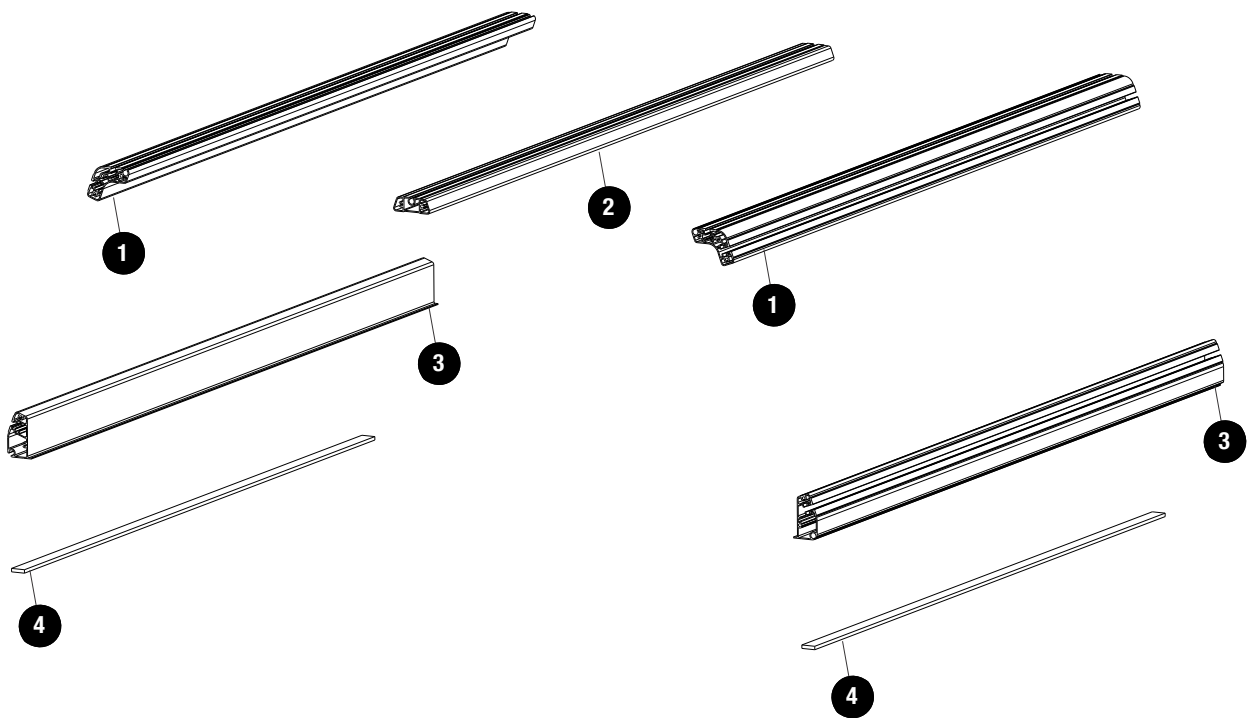

2

FIT AND SECURE

2.1

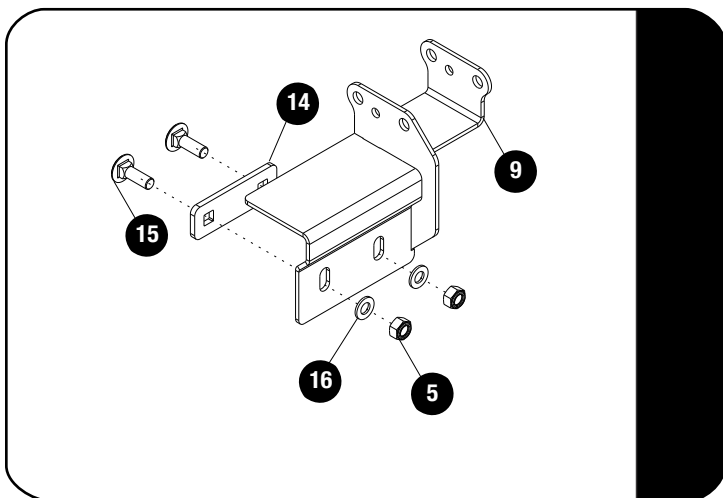

Remove the factory rail end caps.
Slide 2 channel plates (Item 14) into each rail

Loosly assemble the Front Mount Brackets (item 9) using the carriage bolts, M8x16x1.6 Flat washer and M8 Nyloc Nut (Item 15,16 & 5).

Do this on both the LH and RH side

Note LH and RH Front Channel mount position
DO NOT FULLY TIGHTEN

2.2

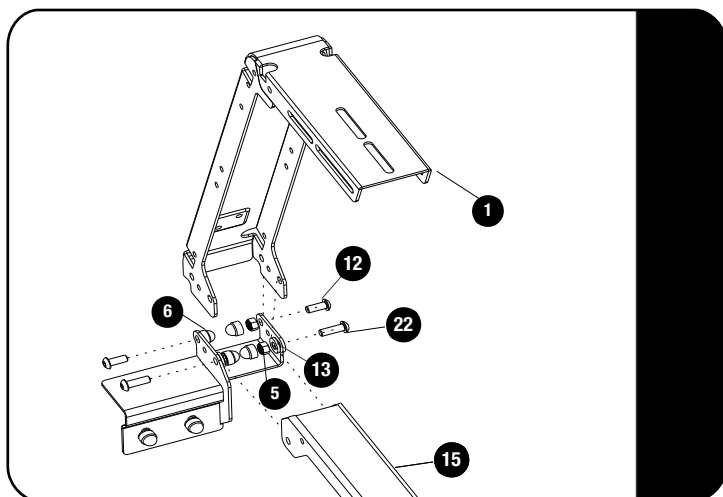

Assemble the Pro Bed Leg (Item 1) to the Front Channel Mount (Item 9) using M8x25 Button head screw, M8x19x3 Flat Washer and M8 Nyloc Nut (Item 22,13 & 5) as shown and M8x20 Button head screw and M8 nyloc Nut (Item 12 & 5).

Do this on both the LH and RH side

DO NOT FULLY TIGHTEN

2.3

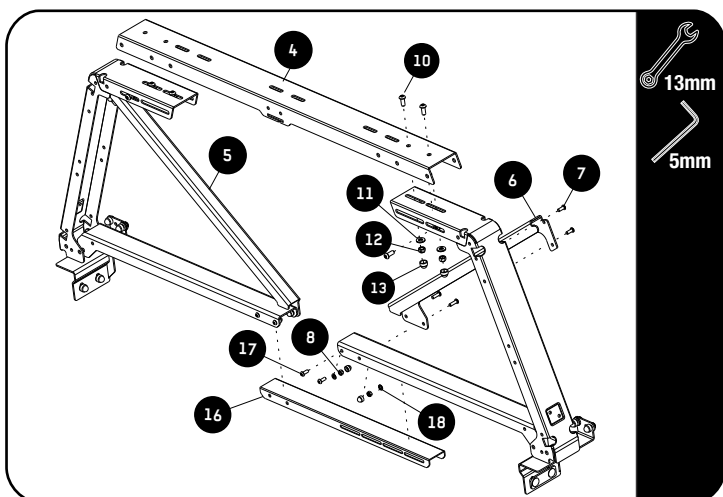

Assemble the Front Diagonal and Horizontal Brace parts as shown (Item 4,5 & 6) to the legs fitted in 2.2 using the M8x20 Button head screws, M8x19x2 Flat washer and M8 Nyloc Nut (Item 10,11 & 12).

FULLY TIGHTEN.

Use the M6x20 Button head Screws, M6x12x1 Flat washer and M6 Nyloc Nut (Item 8,17 & 18) to fit the Front Center Brace to the LH and RH Front Horizontal Braces (Item 16).

DO NOT FULLY TIGHTEN

2.4

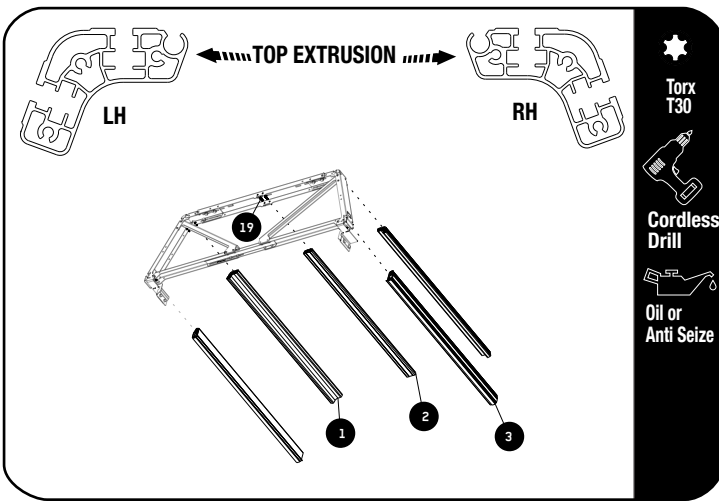

Slide the front leg and truss assembly backward to allow access for securing extrusions.



Take note of extrusion orientation !

Using the supplied T30 6" torx bit and a cordless driver fit the extrusion using the M6x25 thread forming screws (Item 19). Use a slow and constant speed when using the cordless driver.



Use a little anti seize or oil on screw threads before inserting. Note these are Thread Forming Screws.

When complete slide assembly forward in the cargo rails giving room for rear legs to be assembled.



Tightening Torque 25Nm / 18.4 ft lbs

2.5

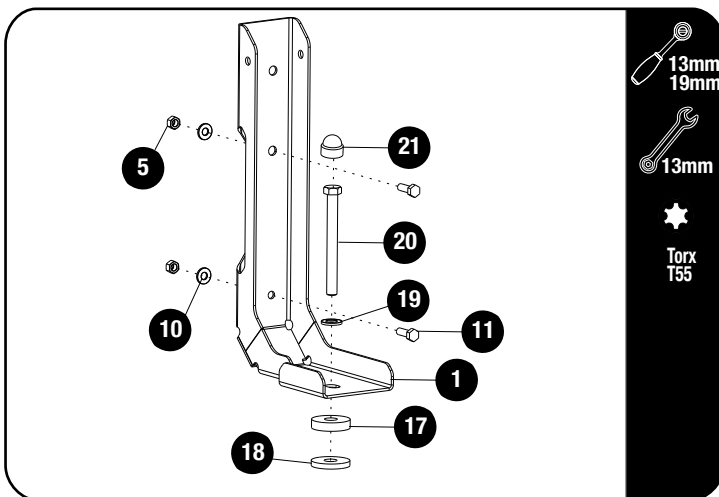

Remove the 2 rear factory bed bolts using a T55 Torx Bit.

Position the rear Bed Stiffener's by the rear bed pillars, aligning the base hole over the hole of the M12 bolt removed earlier

Mark the 3 holes on both LH and RH stiffener brackets. Remove both the rear tail lights (check on Youtube for help). Drill the 3 holes using a 4mm as a pilot hole and open all up to 9mm. Use anti rust on the Holes.

Place the 6mm and 10mm bed spacer (Item 17&18) over the bed bolt hole. Loosely fit the M12 bed bolt and M12 Flat washer (Item 19&20) before inserting and fully tightening the two M8x25 Hex Bolts, M8x19x2 Flat Washer and M8 Nyloc Nut (Item 10, 11&5). When done Fully tighten the M12 bed bolt. Place the M12 Nut cap (Item 21) to the M12 Hex Bolt.

2.6

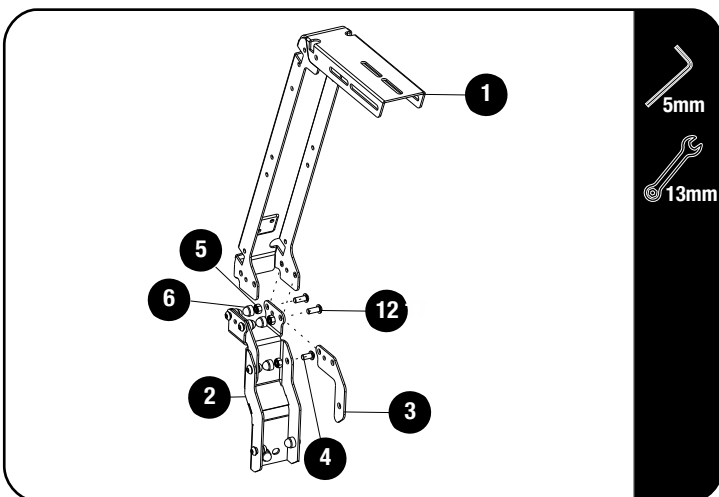

Assemble the Pro Bed Rack Leg (Item 1) to the rear top main bracket (Item 2) using the rear gusset (Item 3) and M8x16 Button head screw and M8 nyloc Nut as shown.

Assemble the M8x20 Button head screw and M8 Nyloc Nut (Item 12&5) and fully tighten all the bolts.



Tightening Torque:

M8 : 15-20Nm / 11.06 ft lb - 14.75 ft lb

2

FIT AND SECURE

2.7

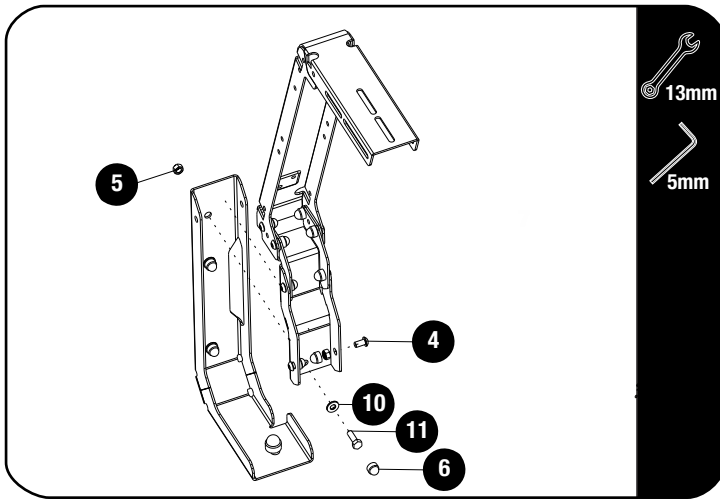

Fit the leg assembly to the bed stiffener installed earlier using the M8x25 Hex Bolt, M8x19x2 Flat Washer and M8 Nyloc Nut (Item 10,11&5).

Fit the M8x16 Button Head screws as shown into the side of the brackets together with the M8 Nyloc nuts (Item 4&5).

Fully tighten all the bolts on the leg assembly and place nut caps where needed.

REFIT BOTH REAR TAIL LIGHTS.



Tightening Torque:

M8 : 15-20Nm / 11.06 ft lb - 14.75 ft lb

2.8

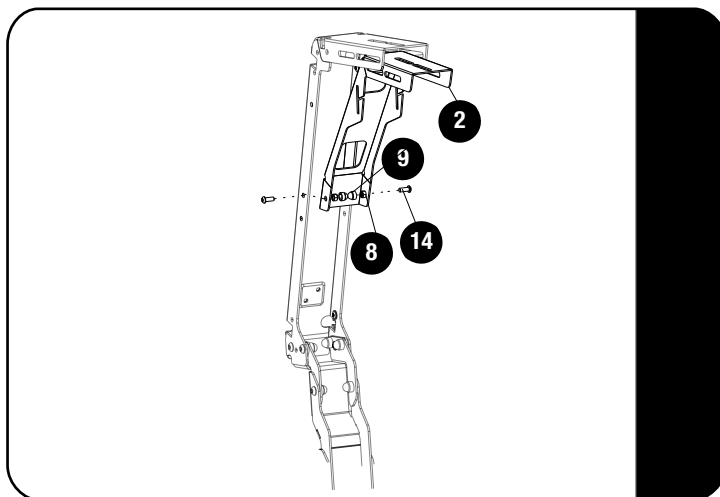

Fit the Rear Brace (Item 2) using the M6x12 button head screws and M6 Nyloc nuts (Item 14 & 8).

Fully tighten and place M6 Nut caps (Item 9) on the M6 Nyloc Nuts.



Tightening Torque:

M6 : 8-10Nm / 5.9 ft lb - 7.38 ft lb

2.9

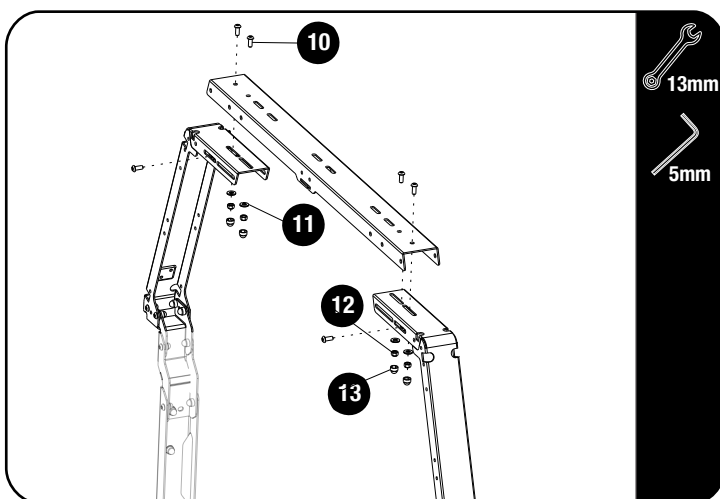

Loosely assemble the rear top truss using the M8x20 Button head screws, M8x19x2 Flat washer and M8 Nyloc Nuts (Item 10,11&12). Fully tighten the M8 Button Heads and place M8 Nut Caps on the M8 Nyloc Nuts (Item 13).



Tightening Torque:

M8 : 15-20Nm / 11.06 ft lb - 14.75 ft lb

2

FIT AND SECURE

2.10

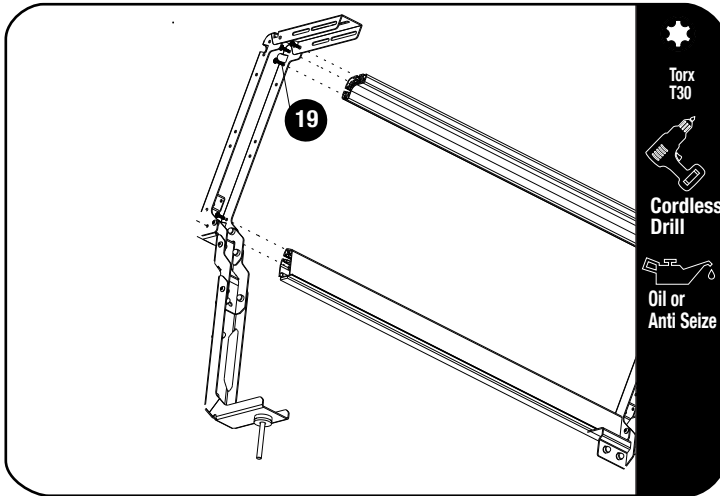

↻ Pull the front leg / truss / extrusion assembly toward the rear legs. Attach the rear leg assembly to the Extrusions using the M6x25 thread forming screws (Item 19) and a cordless driver. The front assembly will be pulled back into its final position while fully tightening these screws.

⚠ Use a little anti seize or oil on screw threads before inserting. Note these are Thread Forming Screws.

⚠ Tightening Torque 25Nm / 18.4 ft lbs

2.11

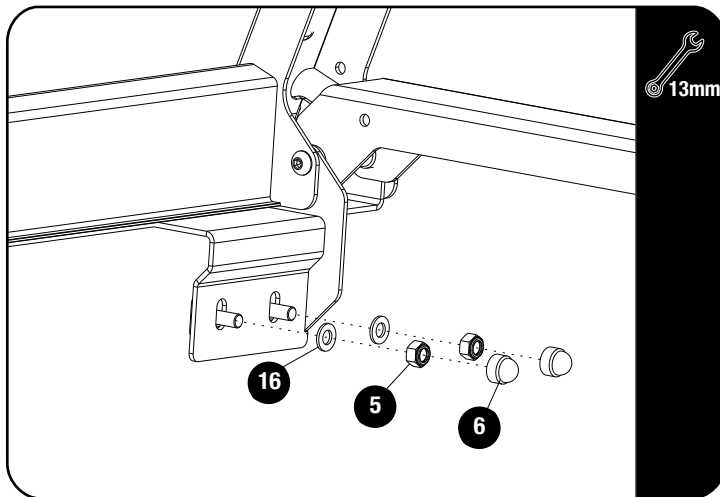

↻ With the Load Bed rack in Position fully tighten the bracket fitted in 2.1. Place M8 Nut caps (Item 6) onto the M8 Nyloc nuts (Item 5).

⚠ Tightening Torque:
M8 : 15-20Nm / 11.06 ft lb - 14.75 ft lb

2.12

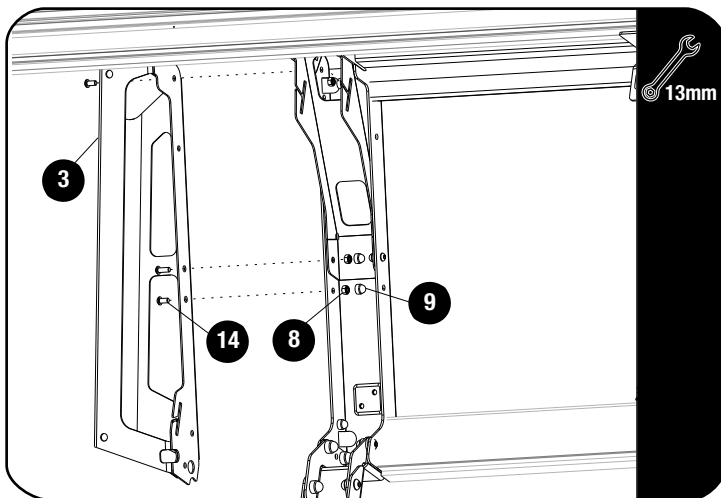

↻ Using clamps and a spirit level clamp the spirit level to the inside of the Front Center Brace and Tighten the M6x20 Button head screws and M6 Nyloc Nuts fitted in 2.3. Place M6 Nut caps on the M6 Nyloc Nuts.

2**FIT AND SECURE****2.13**

 Assemble the Rear Wing Brackets (Item 3) using the M6x12 Button head screws and M6 Nyloc Nuts (Item 14 & 8).

Place the M6 Nut caps (Item 9) over the nyloc nuts.

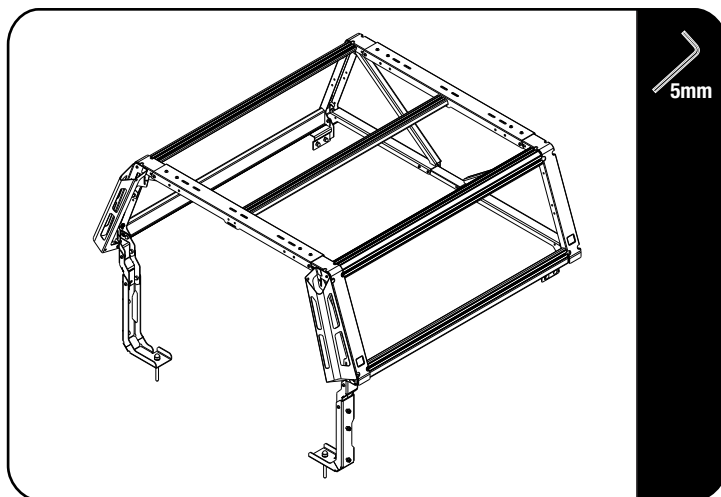
2.14

 Fully tighten all the bolts and nuts and place nut caps where needed.

6

COMPLETION

6.1

Congratulations! You did it. Take a step back and admire your work!



7

INSTALL OTHER VEHICLE AND RACK ACCESSORIES

Now's the time to visit your favorite Front Runner dealer in person or online.

IMPORTANT!

FRONT RUNNER RACK KITS OFTEN HAVE A HIGHER LOAD RATING THAN THE VEHICLES THEY ARE MOUNTED TO. PLEASE REFER TO YOUR SPECIFIC VEHICLE MANUFACTURER FOR A RECOMMENDED ROOF RATING. FRONT RUNNER CANNOT BE RESPONSIBLE FOR IMPROPER LOADING BEYOND THE VEHICLE MANUFACTURER'S STATED LOAD CAPACITY.

Be sure to tag us. We love to see our gear in action! #FrontRunnerOutfitters #BornToRoam

Share your adventures on: 