

# START HERE!

## READ ME FIRST

Don't be a hero and muscle through this installation without reading these fitting instructions first! Improper installation of this gear may void certain aspects of your warranty.

Before you begin, take a moment and open all your Front Runner rack kit boxes and gather the assembly instructions for the various components.

A complete kit will contain:

1. A Front Runner Mounting system specific to your vehicle
2. A Front Runner Rack Tray or Load bar Slats

This document will guide you through the assembly of the mounting system and assist you in fitting the roof rack tray or load bars to your specific vehicle.

Please refer to the next page for a list of all the components, quantities and tools required.

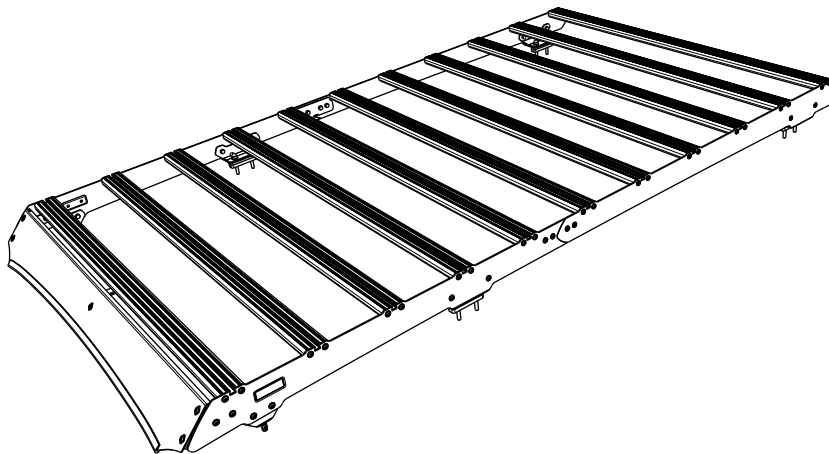

### IMPORTANT WARNING!

IT IS CRITICAL THAT ALL FRONT RUNNER PRODUCTS BE PROPERLY AND SECURELY ASSEMBLED AND ATTACHED TO YOUR VEHICLE. IMPROPER ATTACHMENT COULD RESULT IN AN AUTOMOBILE ACCIDENT, AND COULD CAUSE SERIOUS BODILY INJURY OR DEATH. YOU ARE RESPONSIBLE FOR ASSEMBLING AND SECURING ALL FRONT RUNNER PRODUCTS TO YOUR VEHICLE, CHECKING THE ATTACHMENTS PRIOR TO USE, AND PERIODICALLY INSPECTING THE PRODUCTS FOR ADJUSTMENT, WEAR AND DAMAGE. THEREFORE, YOU MUST READ AND UNDERSTAND ALL OF THE INSTRUCTIONS AND PRECAUTIONS SUPPLIED WITH YOUR FRONT RUNNER PRODUCT PRIOR TO INSTALLATION OR USE. IF YOU DO NOT UNDERSTAND ALL OF THE INSTRUCTIONS AND CAUTIONS, OR IF YOU HAVE NO MECHANICAL EXPERIENCE AND ARE NOT THOROUGHLY FAMILIAR WITH THE INSTALLATION PROCEDURES, YOU SHOULD HAVE THE PRODUCT INSTALLED BY A PROFESSIONAL INSTALLER OR OTHER QUALIFIED PERSONNEL.

**NOTE:** Front Runner will not be responsible for any damage caused by the failure to install the product according to these instructions.

Please call us if you have any questions about the installation of this product.



# 1 GET ORGANIZED

## IN THE BOX

1	2 X	Foot Rail Front LH / RH
2	2 X	Foot Rail Rear LH / RH
3	2 X	Stiffener Plate 01
4	2 X	Stiffener Plate 02
5	2 X	Stiffener Plate 03
6	2 X	Splice Plate
7	11 X	Slimsport Slat
8	44 X	M6 x 20 Button Head Screw
9	20 X	M6 x 16 Button Head Screw
10	20 X	M6 Nyloc Nut
11	22 X	M6 Nut Cap
12	8 X	10mm Plastic Spacer
13	8 X	M8 x 19 x 12 Flat Washer
14	2 X	M6 x 12 x 1 Flat Washer

## IN THE BOX

15	2 X	M6 x 30 Hex Bolt
16	8 X	M8 x 60 Hex Bolt
17	3 X	Jack Nut Long
18	1 X	Jack Nut Tool
19	2 X	M6 x 30 Button Head
20	8 X	M8 Nut Cap

## TOOLS NEEDED

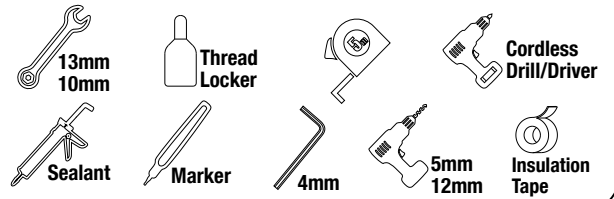
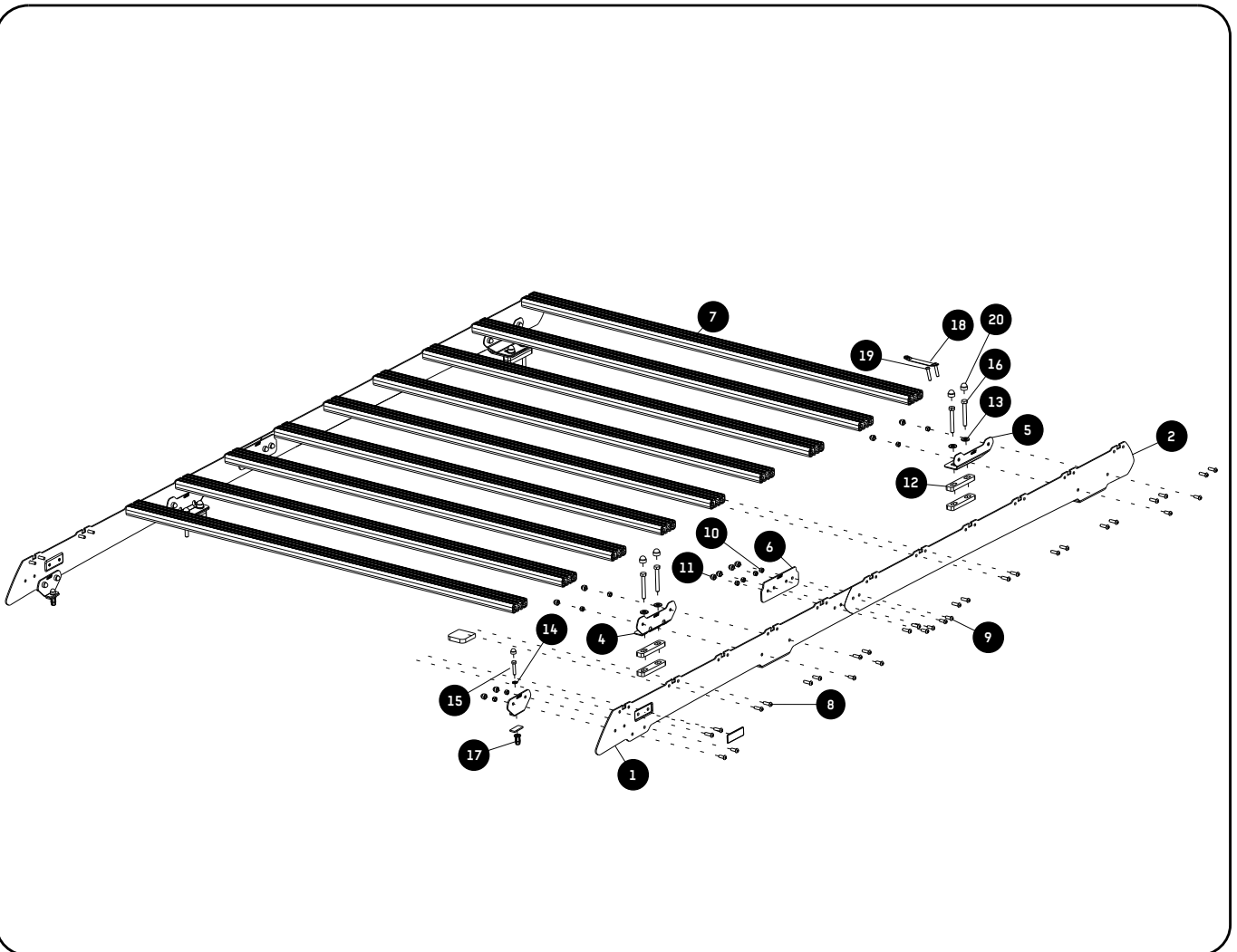

FIGURE 1.1



## 2

## ASSEMBLY

2.1

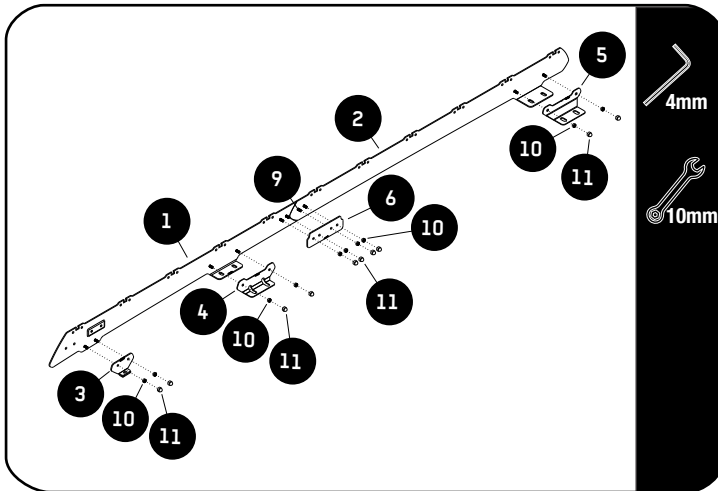

Secure the Splice Plates (Item 6) to the Foot Rails (Items 1 & 2) as shown using M6 x 16 Button Head Bolts and M6 Nyloc Nuts (Items 9 & 10).

Secure the Stiffener Plates (Items 3, 4, & 5) to the Foot Rails (Items 1 & 2) using M6 x 16 Button Head Bolts and M6 Nyloc Nuts (Items 9 & 10)

Fully Tighten all M6 x 16 Button Head bolts.

Place M6 Nut Caps (Item 11) over all Nyloc Nuts.

Do this to both LH & RH Foot Rails.



**Tightening Torque 8-10Nm / 5.9 ft lb - 7.38 ft lb. Take care when using a cordless driver.**

2.2

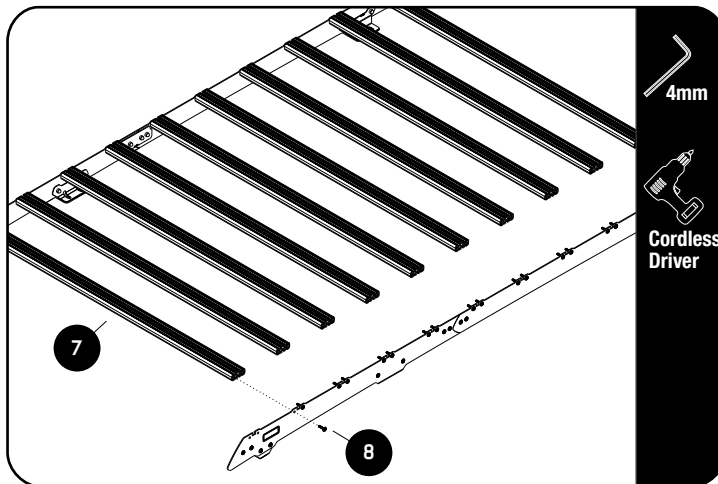

Fit 10 Slimsport Slats (Item 7) to assembly 2.1 using M6 x 20 Button Head Screws (Item 8).



**Note do not fit front slat.**



**Apply a little Thread Locker on screw threads before inserting.**



**Tightening Torque 8-10Nm / 5.9 ft lb - 7.38 ft lb. Take care when using a cordless driver.**

## 3

## PREPERATION

3.1

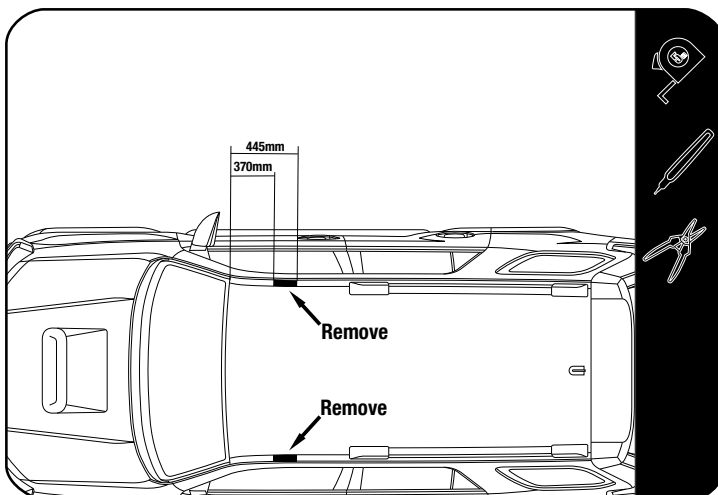

With the factory roof rails removed and measuring from the front edge of the ditch trim, mark the measurements shown on both LH & RH ditch trims.

Using snips cut and remove the section shown in 3.1

3.2

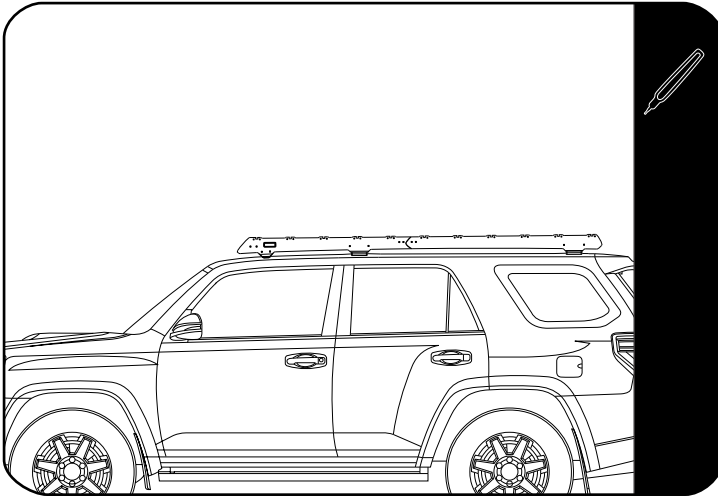

With the help of a Friend Place the assembled Rack on the vehicle, lining up the holes in the foot rail with the factory holes in the roof. Mark the hole centres where the ditch moldings were cut out.

Remove the Rack.

3.3

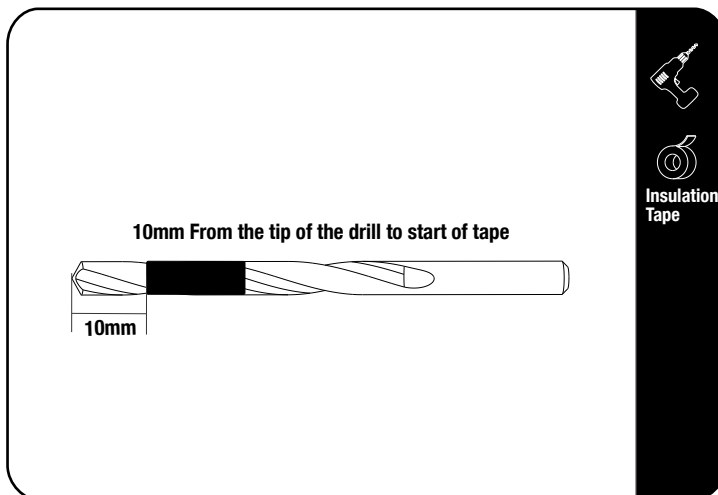

Before drilling wrap a band of tape around both the 5mm & 12mm drill bits as a depth guide.



**NOTE:** Take care as there are air bags located below this area.



Insulation Tape

Start with a 5mm pilot hole before opening to a 12mm.

3.4



Insert the M6 Button Head Bolt (Item 21) into the one side of the Installer Wrench (Item 20), loosely fit a Jack Nut (Item 19) to the Button Head Bolt as shown.

Using the Installer Wrench and a M6 x 30 Button Head Bolt, insert the M6 Jack Nuts into the holes drilled.

Place the Assembly into the holes drilled in 3.3. Using a battery powered screw driver and a 4mm Allen Key Bit, set the Jack Nut into the hole while holding onto the handle of the Installer Wrench.



**Make sure that the Jack Nut has pulled up all the way to the inside skin of the roof panel.**



Cordless Driver

4.1

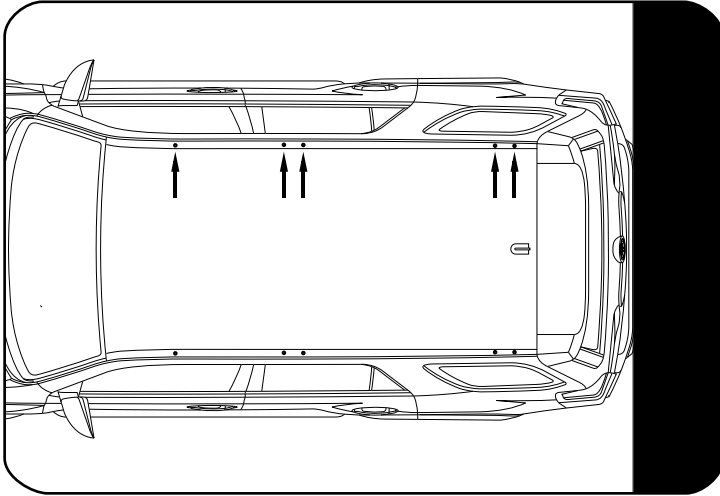

Apply sealant over each of the holes at the front, mid and rear points

Place Spacers (Item 12) over the mounting holes.

4.2

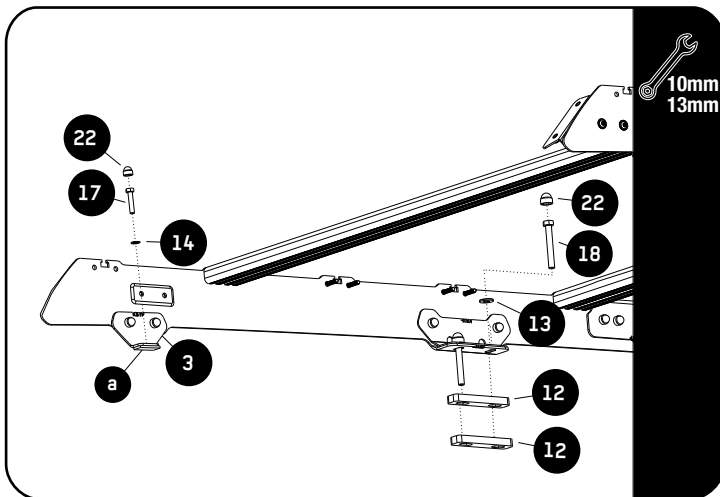

Remove the backing from the double sided tape (4.2a) on the bottom of the Support Plate 01 (Item 3) and push the plate firmly down onto the body of the vehicle.

Secure Rack assembly 2.2 using M6 x 12 x 1 Flat Washers, M6 x 30 Hex Bolts for front foot (Items 15 & 17).



Place a bead of silicone down the length of each M6x20 bolt before inserting.

Secure the middle and back feet using M8 x 19 x 2 Flat Washers and M8 x 60 Hex Bolts (Item 18, 13).



Fasten the front foot by inserting the fastener (item 17) through the double sided tape and securing into the Jack Nut fitted earlier.

Fully tighten all fasteners.

Place M6 and M8 Nut Caps over all hex Bolts.

5.1

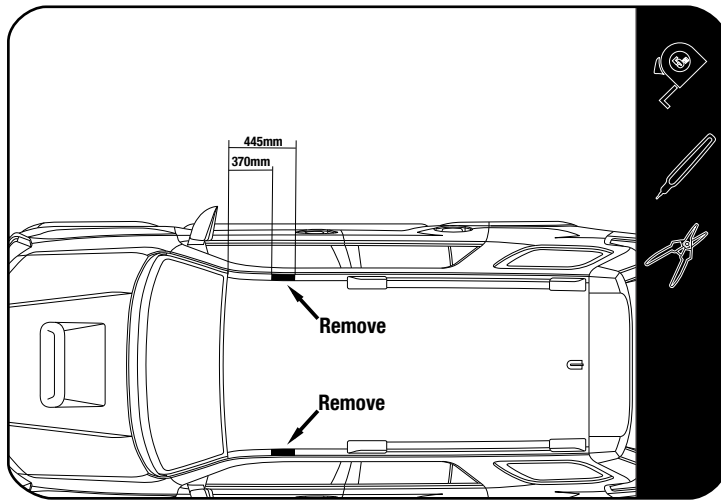

With the factory roof rails removed and measuring from the front edge of the ditch trim, mark the measurements shown on both LH & RH ditch trims.

Using snips cut and remove the section shown in 5.1

5.2



Use denatured alchohol and ensure the ditch is clean from any residue where the Support Plate 01 (Item 3) will be resting on the ditch.

6.1

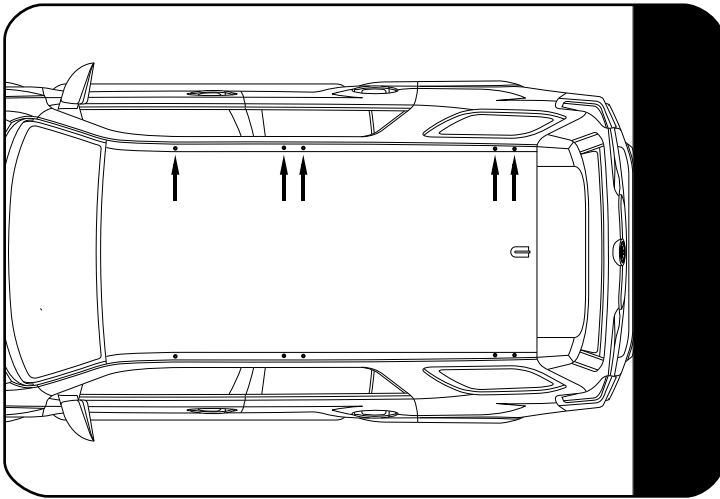

Apply sealant over each of the holes at the mid and rear points.

Place Spacers (Item 12) over the mounting holes.

6.2

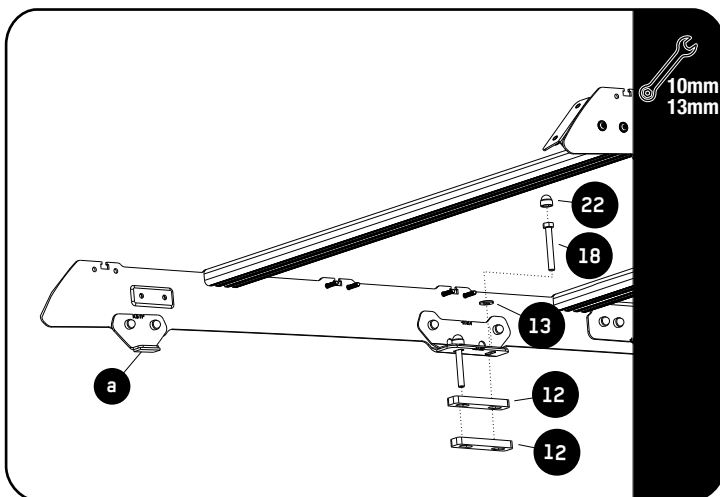

Remove the backing from the double sided tape (4.2a) on the bottom of the Support Plate 01 (Item 3) and push the plate firmly down onto the body of the vehicle.

Secure Rack assembly 2.2 using M6 x 12 x 1 Flat Washers, M6 x 30 Hex Bolts for front foot (Items 15 & 17).

Secure the middle and back feet using M8 x 19 x 2 Flat Washers and M8 x 60 Hex Bolts (Item 18, 13).

Fully tighten all fasteners.

Place M6 and M8 Nut Caps over all hex Bolts.



**Tightening Torque 8-10Nm / 5.9 ft lb - 7.38 ft lb. Take care when using a cordless driver.**

7.1

**STANDARD WIND FAIRING ASSEMBLY**

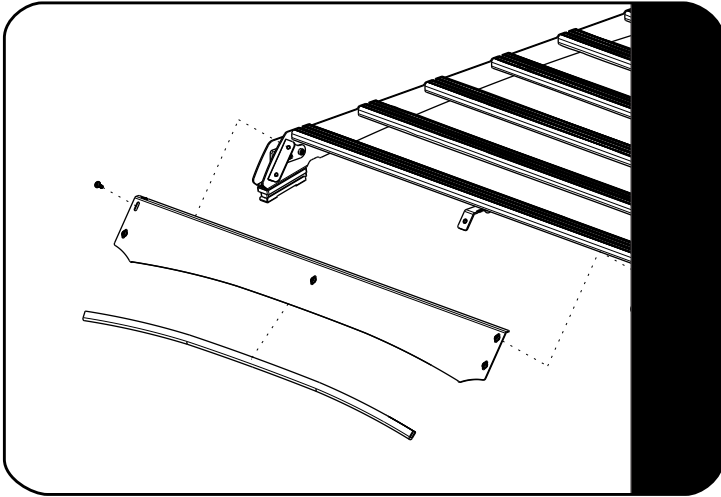

Refer to fitment guide RRAC234

7.2

**LIGHT BAR WIND FAIRING ASSEMBLY**

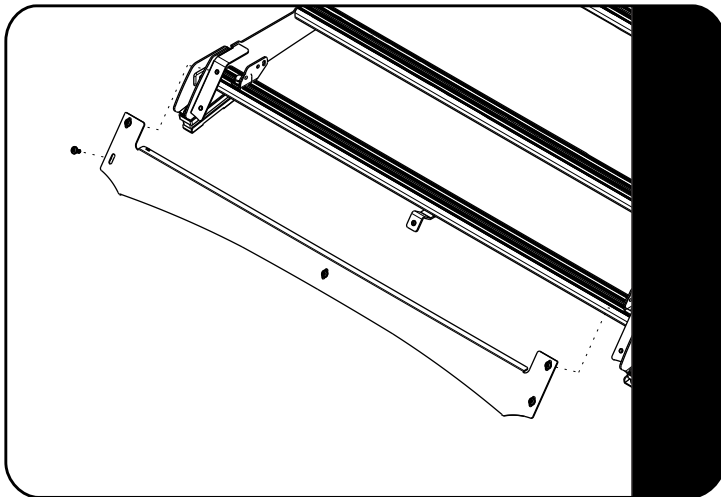

Refer to fitment guide RRAC195

8

## COMPLETION

8.1

Congratulations! You did it. Take a step back and admire your work!



9

## INSTALL OTHER VEHICLE AND RACK ACCESSORIES

Now's the time to visit your favorite Front Runner dealer in person or online.

### IMPORTANT!

FRONT RUNNER RACK KITS OFTEN HAVE A HIGHER LOAD RATING THAN THE VEHICLES THEY ARE MOUNTED TO. PLEASE REFER TO YOUR SPECIFIC VEHICLE MANUFACTURER FOR A RECOMMENDED ROOF RATING. FRONT RUNNER CANNOT BE RESPONSIBLE FOR IMPROPER LOADING BEYOND THE VEHICLE MANUFACTURER'S STATED LOAD CAPACITY.

Be sure to tag us. We love to see our gear in action! #FrontRunnerOutfitters #BornToRoam

Share your adventures on: 